

INSTALLATION, OPERATING AND SERVICE INSTRUCTIONS EVOLUTION OUTDOOR WATER HEATER MODULATION

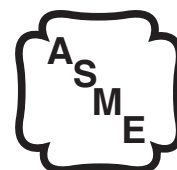

<p>For Service and repairs to the heating plant, call your heating contractor. When seeking information on the water heater from the manufacturer, provide water heater model and serial number as shown on rating label.</p>			
Water Heater Model EVOW-	Installation Date	Serial Number	Type System
Heating Contractor			
Address			Phone Number

Your Local Thermal Solutions Representative:



IMPORTANT INFORMATION - READ CAREFULLY

NOTE: Post these instructions and maintain in legible condition.

NOTE: The equipment shall be installed in accordance with those installation regulations required in the area where the installation is to be made. These regulations shall be carefully followed in all cases. Authorities having jurisdiction shall be consulted before installations are made.

All wiring on this appliance when installed in the USA shall be in accordance with the National Electrical Code and/or local regulations.

All wiring on this appliance when installed in Canada shall be in accordance with the Canadian Electrical Code and/or local regulations.

The following terms are used throughout this manual to bring attention to the presence of hazards of various risk levels, or to important information concerning product life.

DANGER

Indicates an imminently hazardous situation which, if not avoided, will result in death, serious injury or substantial property damage.

CAUTION

Indicates a potentially hazardous situation which, if not avoided could result in death, serious injury or substantial property damage.

WARNING

Indicates a potentially hazardous situation which, if not avoided could result in death, serious injury or substantial property damage.

NOTICE

Indicates special instructions on installation, operation, or maintenance which are important but not related to personal injury hazards.

WARNING: If the information in these instructions is not followed exactly, a fire or explosion may result causing property damage, personal injury or death.

Do not store or use gasoline or other flammable vapors and liquids in the vicinity of this or any other appliance.

WHAT TO DO IF YOU SMELL GAS

- Do not try to light any appliance.
- Do not touch any electrical switch; do not use any phone in your building.
- Immediately call your gas supplier from a neighbor's phone. Follow the gas supplier's instructions.
- If you cannot reach your gas supplier, call the fire department.

Installation and service must be performed by a qualified installer, service agency or the gas supplier.

AVERTISSEMENT. Assurez-vous de bien suivre les instructions données dans cette notice pour réduire au minimum le risque d'incendie ou d'explosion ou pour éviter tout dommage matériel, toute blessure ou la mort.

Ne pas entreposer ni utiliser d'essence ou ni d'autres vapeurs ou liquides inflammables à proximité de cet appareil ou de tout autre appareil.

QUE FAIRE SI VOUS SENTEZ UNE ODEUR DE GAZ :

- Ne pas tenter d'allumer d'appareil.
- Ne touchez à aucun interrupteur ; ne pas vous servir des téléphones se trouvant dans le bâtiment.
- Appelez immédiatement votre fournisseur de gaz depuis un voisin. Suivez les instructions du fournisseur.
- Si vous ne pouvez rejoindre le fournisseur, appelez le service des incendies.

L'installation et l'entretien doivent être assurés par un installateur ou un service d'entretien qualifié ou par le fournisseur de gaz.

WARNING

This water heater requires regular maintenance and service to operate safely. Follow the instructions contained in this manual.

Improper installation, adjustment, alteration, service or maintenance can cause property damage, person injury or loss of life. Read and understand the entire manual before attempting installation, start-up operation, or service. Installation and service must be performed only by an experienced, skilled installer or service agency.

The water heater must be properly vented.

This water heater needs fresh air for safe operation and must be installed so there are provisions for adequate combustion and ventilation air.

The interior of the venting and air intake systems must be inspected and cleaned annually and should be inspected periodically for any obstructions. Clean and unobstructed venting and air intake systems are necessary to allow noxious fumes that cause injury or loss of life to vent safely and will contribute toward maintaining the water heater's efficiency.

Installation is not complete unless a factory supplied pressure relief valve is installed on the water heater - see Installation section of this manual for details.

This water heater is supplied with safety devices which may cause the appliance to shut down and not re-start without service - if damage due to frozen pipes is a possibility, the domestic hot water system should not be left unattended in cold weather; or appropriate safeguards and alarms should be installed on the system to prevent damage if the water heater is inoperative.

This water heater contains very hot water under high pressure. Do not unscrew any pipe fittings nor attempt to disconnect any components of this water heater without positively assuring the water is cool and has no pressure. Always wear protective clothing and equipment when installing, starting up or servicing this water heater to prevent scald injuries. Do not rely on the pressure and temperature gauges to determine the temperature and pressure of the water heater. This water heater contains components which become very hot when the water heater is operating. Do not touch any components unless they are cool.

Water heater materials of construction, products of combustion and fuel contain alumina, silica, heavy metals, carbon monoxide, nitrogen oxides, aldehydes and/or other toxic or harmful substances which can cause death or serious injury and which are known to the state of California to cause cancer, birth defects and other reproductive harm. Always use proper safety clothing, respirators and equipment when servicing or working nearby the appliance.

Failure to follow all instructions in the proper order can cause personal injury or death. Read all instructions, including all those contained in component manufacturers manuals which are provided with the water heater before installing, starting up, operating, maintaining or servicing.

Keep water heater area clear and free from combustible materials, gasoline and other flammable vapors or liquids.

All cover plates, enclosures and guards must be in place at all times.

This product must be installed by a licensed plumber or gas fitter when installed within the Commonwealth of Massachusetts.

This water heater has a limited warranty, a copy of which is printed on the back of this manual. It is the responsibility of the installing contractor to see that all controls are correctly installed and are operating properly when the installation is complete.

Table of Contents

I. Pre-Installation	6		
II. Unpacking the Water Heater	8	F. Annual Inspection and Check.	45
III. Installation	9	G. Air Filter:	46
A. Vent Guidelines Due to Removal of an Existing Appliance	9	H. Pilot and Main Flame:	46
B. VENTING	9	I. Check Combustion and Safety Controls:	47
C. COMBUSTION AIR	18	J. Burner:	47
D. Venting Materials	20	K. Safety and Operating Controls, Operation and Shutdown	48
E. WATER TREATMENT	21	L. Troubleshooting Guide	50
F. WATER PIPING AND TRIM	22	M. NORMAL SEQUENCE OF OPERATION	52
G. GAS PIPING	25	VII. Repair Parts	53
H. ELECTRICAL	29	VIII. Temperature Controller Operation	70
I. MODULAR SYSTEMS	31	A. Description	70
J. CONDENSATE DRAINS	35	B. Set-Up	70
IV. System Start-up	37	C. Adjustments	71
V. Operation	40	D. Other	71
VI. Service/Maintenance	44		
A. General Guidelines	44		
B. Daily Water Heater Inspection & Check	45		
C. Weekly Water Heater Inspection & Check	45		
D. Monthly Safety and Operating Control Checks	45		
E. Semi-Annual "Tune-up"	45		

NOTICE

Modular systems (two or more EVO Series water heaters) may be installed with zero (0) side clearances between the water heaters

Minimum Clearance to Combustible Materials

Left Side	Right Side	Front	Rear	Top	Flue Connector
6"	6"	24"	6"	6"	18"

Recommended Clearance for Service

	Left Side or Right Side	Front	Rear	Top
750	24"	24"	24"	16"
1000	24"	24"	24"	16"
1500	24"	24"	24"	19"
2000	24"	24"	24"	31"

* When 3 or more units are mounted side-by-side, front service clearance increases by 12" and the rear service clearance increases by 24".

NOTE: Verify clearance with local codes.

WATER HEATER MODEL	DIMENSION																						
	'A'	'B'	'C'	'E'	'F'	'G'	'H'	'J'	'K'	'L'	'M'	'N'	'P'	'Q'	'R'	'S'	'T'	'U'	'V'	'W'	'X'	'Y'	'Z'
EVA-750	61	28½	30½	30½	17½	7	4½	21½	14½	19	3	1½	4	6	6½	13½	23½	9½	3½	19½	9½	6½	16
EVA-1000	67½	28½	30½	36½	17½	7	4½	21½	14½	19	3	1½	6	6	6½	13½	23½	9½	3½	19½	9½	6½	16
EVA-1500	79½	28½	30½	49	17½	7	4½	21½	27½	19	3	1½	6	8	6½	13½	23½	9½	3½	19½	9½	6½	19
EVA-2000	91½	28½	30½	61½	17½	7	4½	21½	27½	19	3	1½	6	8	6½	13½	23½	9½	3½	19½	9½	6½	31

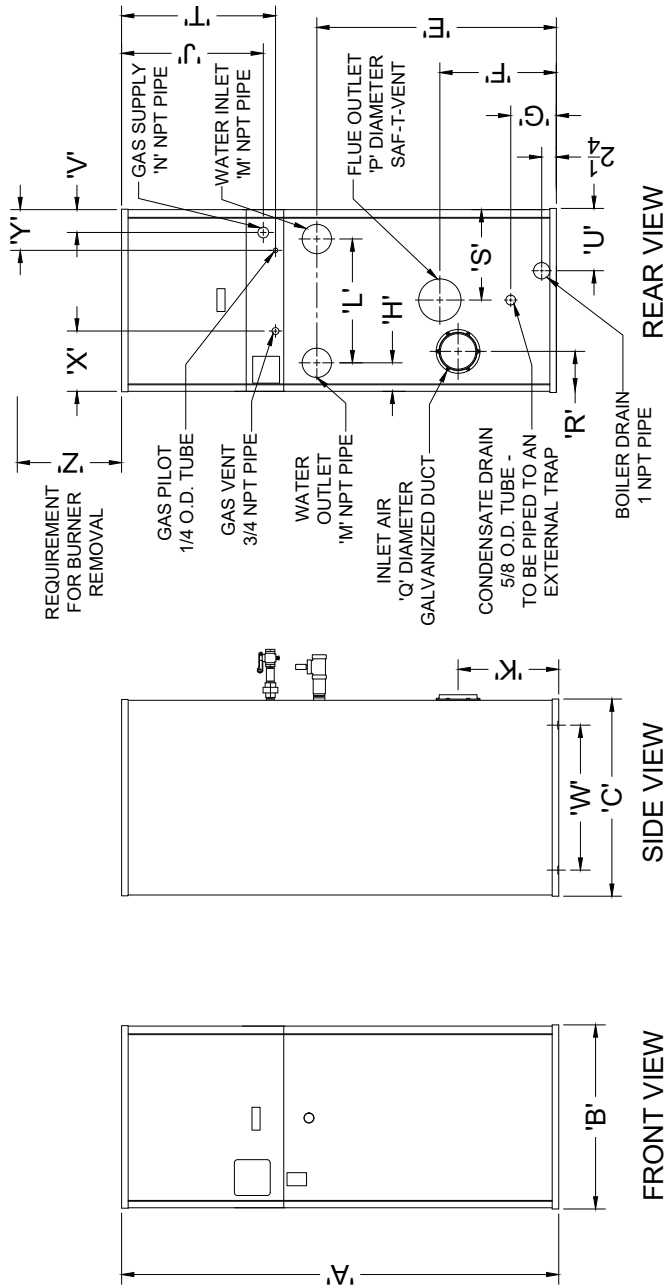

WATER HEATER MODEL	MOTOR (HP)	STANDARD ELECTRICAL SUPPLY (VOLTS/HERTZ/PHASE)	TOTAL CURRENT DRAW	
			ON/OFF (AMPS)	MOD (AMPS)
750/2000	1½	120/60/1	17.7	4.96
		208/60/1	9.2	4.96
		230/60/1	9.2	4.96
		208/60/3	5.2	4.96
		230/60/3	4.96	4.96
		480/60/3	2.83	2.83

WATER HEATER MODEL	CAPACITIES					
	BTU INPUT	BTU OUTPUT	WATER VOLUME (GALLONS)	HEAT TRANSFER AREA (SQ. FT.)	DRY WEIGHT (LBS.)	WET WEIGHT (LBS.)
EVA-750	750,000	660,000	15.9	131	1172	1305
EVA-1000	1,000,000	880,000	16.4	175	1260	1397
EVA-1500	1,500,000	1,320,000	17.4	264	1402	1547
EVA-2000	2,000,000	1,760,000	18.5	352	1536	1690

Figure 1: Dimensions and Capacities

I. Pre-Installation

WARNING

Carefully read all instructions before installing water heater. Failure to follow all instructions in proper order can cause personal injury or death.

- A. Installation must conform to the requirements of the authority having jurisdiction. In the absence of such requirements, installation must conform to the National Fuel Gas Code, NFPA 54/ANSI Z223.1, and/or CAN/CGA B149.1 Natural Gas and Propane Installation Code. Where required by the authority having jurisdiction, the installation must conform to the Standard for Controls and Safety Devices for Automatically Fired Boilers, ANSI/ASME CSD-1.
- B. The water heater is not design certified for installation on combustible flooring. The water heater must not be installed on carpeting.
- C. This water heater is designed for outdoor or indoor installation.
- D. Provide clearance between water heater jacket and combustible material in accordance with local fire ordinance. Refer to page 4 of this manual for minimum listed clearance from combustible material.
- E. Install on level floor. For basement installation provide concrete base if floor is not perfectly level or if water may be encountered on floor around water heater. Floor must be able to support weight of water heater, water and all additional system components.
- F. Protect gas ignition system components from water (dripping, spraying, rain, etc.) during water heater operation and service (circulator replacement, condensate trap service, control replacement, etc.).
- G. Provide combustion and ventilation air in accordance with applicable provisions of local building codes or: USA - National Fuel Gas Code, NFPA 54/ANSI Z223.1, Section 5.3, Air for Combustion and Ventilation; Canada - Natural Gas Installation Code, CAN/CGA - B149.1, or Propane Installation Code, CAN/CGA - B.149.2, Part 5, Venting Systems and Air Supply for Appliances.
- H. Locate the water heater in an area where leakage of the appliance or connections will not result in damage to the area adjacent to the appliance or to lower floors of the structure. When such location cannot be avoided it is recommended that a suitable drain pan, adequately drained, be installed under the appliance; however, the pan must not restrict combustion air flow.
- I. Provide adequate combustion and ventilation air required for operation of the water heater. Refer to the venting and combustion air sections of this manual for specific instructions.

WARNING

Adequate combustion and ventilation air must be provided to assure proper combustion.

- J. Provide adequate clearance for servicing and proper operation.
- K. For other than direct vent applications, the appliance must be located as close as possible to a chimney or gas vent.

The following guideline is based on the *National Fuel Gas Code*, NFPA 54/ANSI Z223.1.

1. Determine volume of space (boiler room). Rooms communicating directly with space (through openings not furnished with doors) are considered part of space.

$$\text{Volume [ft}^3\text{]} = \text{Length [ft]} \times \text{Width [ft]} \times \text{Height [ft]}$$

2. Determine Total Input of all appliances in space. Round result to nearest 1,000 Btu per hour (Btuh).
3. Determine type of space. Divide Volume by Total Input.
 - a. If result is greater than or equal to 50 ft³ per 1,000 Btuh, space is considered an *unconfined space*.
 - b. If result is less than 50 ft³ per 1,000 Btuh, space is considered a *confined space*.
4. Determine building type. A building of *unusually tight construction* has the following characteristics:
 - a. Walls and ceiling exposed to outside atmosphere have a continuous water vapor retarder with a rating of 1 perm or less with openings gasketed and sealed, and;
 - b. Weather-stripping has been added on opening windows and doors, and;
 - c. Caulking or sealants applied in joints around window and door frames, between sole plates and floors, between wall-ceiling joints, between wall panels, at plumbing and electrical penetrations, and at other openings.

WARNING

For installation and operation only in climates where the ambient temperature will not be less than 32 °F (0 °C).

5. For water heater located in an *unconfined space in a building of other than unusually tight construction*, adequate combustion and ventilation air is normally provided by fresh air infiltration through cracks around windows and doors.

NOTICE

Water heater's operated with sealed combustion are exempt from needing provisions for combustion air from the room, provided air intake piping is installed per code and the instructions in this manual.

6. For water heater located within *unconfined space in building of unusually tight construction* or within *confined space*, provide outdoor air through two permanent openings which communicate directly or by duct with the outdoors or spaces (crawl or attic) freely communicating with the outdoors. Locate one opening within 12 inches of top of space. Locate remaining opening within 12 inches of bottom of space. Minimum dimension of air opening is 3 inches. Size each opening per the following:
 - a. Direct communication with outdoors. Minimum free area of 1 square inch per 4,000 Btu per hour input of all equipment in space.
 - b. Vertical ducts. Minimum free area of 1 square inch per 4,000 Btu per hour input of all equipment in space. Duct cross-sectional area shall be same as opening free area.
 - c. Horizontal ducts. Minimum free area of 1 square inch per 2,000 Btu per hour input of all equipment in space. Duct cross-sectional area shall be same as opening free area.
7. Alternate method for water heaters located within confined space. Use indoor air if two permanent openings communicate directly with additional space(s) of sufficient volume such that combined volume of all spaces meet criteria for unconfined space. Size each opening for minimum free area of 1 square inch per 1,000 Btu per hour input of all equipment in spaces, but not less than 100 square inches.

8. Ventilation Duct Louvers and Grilles. Equip outside openings with louvers to prevent entrance of rain and snow, and screens to prevent entrance of insects and rodents. Louvers and grilles must be fixed in open position or interlocked with equipment to open automatically before burner operation. Screens must not be smaller than ¼ inch mesh.

- a. Consider the blocking effect of louvers, grilles and screens when calculating the opening size to provide the required free area. If free area of louver or grille is not known, assume wood louvers have 20-25 percent free area and metal louvers and grilles have 60-75 percent free area.

DANGER

Do not install water heater where gasoline or other flammable vapors or liquids, or sources of hydrocarbons (i.e. bleaches, cleaners, chemicals, sprays, paint removers, fabric softeners, etc.) are used or stored.

NOTICE

Due to the low water content of the water heater, incorrect sizing of the water heater with regard to the heating system load will result in excessive cycling and accelerated component failure. Thermal Solutions DOES NOT warrant failures caused by incorrectly sized water heater applications. DO NOT oversize the water heater to the system. Modular water heaters greatly reduce the likelihood of oversizing.

II. Unpacking the Water Heater

- A. Move water heater to approximate installed position.
- B. Remove all crate fasteners.
- C. Open outside container and remove all inside protective spacers and bracing.
- D. Remove all appliance hold-down fasteners.
- E. Remove unit from shipping skid (if provided).
 1. Tilt the Water Heater to one side and slide a small roller under the raised base.
 2. Tilt the Water Heater to the other side and slide another roller under the base.
 3. Place a larger pipe roller on floor behind the skid.
 4. Roll the Water Heater forward or backward off the skid and onto the pipe roller.
- F. Move Water Heater to its permanent location.

NOTICE

Water heater crate is equipped with a tip & tell label. If label indicates water heater has been tipped over during shipping, remove crate and inspect before trucker leaves.

WARNING

Installation of this appliance should be undertaken only by trained and skilled personnel from a qualified service agency.

CAUTION

Do not drop water heater. Do not bump water heater jacket against floor.

NOTICE

For installation and operation only in climates where the ambient temperature will not be less than 32 °F (0 °C).

For outdoor installation only. Do not install this water heater under an overhang less than 3 feet from its top. The area under the overhang must be open on 3 sides. Installer à l'extérieur seulement.»
Ne pas installer ce chauffe-eau sous une saillie mesurant moins de 3 pi de hauteur. La partie sous la saillie doit être couverte sur 3 côtés.

III. Installation

A. Vent Guidelines Due to Removal of an Existing Appliance

For installations not involving the replacement of an existing appliance, proceed to step B.

When an existing appliance is removed from a common venting system, the common venting system is likely to be too large proper venting of the remaining appliances. At the time of removal of an existing water heater, the following steps shall be followed with each appliance remaining connected to the common venting system placed in operation, while the other appliances remaining connected to the common venting system are not in operation:

1. Seal any unused openings in the common venting system.
2. Visually inspect the venting system for proper size and horizontal pitch and determine there is no blockage or restriction, leakage, corrosion, and other deficiencies which could cause an unsafe condition.
3. Insofar as is practical, close all building doors and windows and all doors between the space in which the appliances remaining connected to the common venting system are located and other spaces of the building. Turn on clothes dryers and any appliance not connected to the common venting system. Turn on any exhaust fans, such as range-hoods and bathroom exhausts, so they will operate at maximum speed. Do not operate a summer exhaust fan. Close fireplace dampers.
4. Place in operation the appliance being inspected. Follow the Lighting (or Operating) Instructions. Adjust thermostat so appliance will operate continuously.
5. Test for Spillage at the draft hood relief opening after five (5) minutes of main burner operation. Use the flame of a match or candle, or smoke from a cigarette, cigar, or pipe.
6. After it has been determined that each appliance remaining connected to the common venting system properly vents when tested as outlined above, return doors, windows, exhaust fans, fire place dampers and any other gas burning appliance to their previous conditions of use.
7. Any improper operation of the common venting system should be corrected so the installation conforms with the *National Fuel Gas Code*, NFPA 54/ANSI Z223.1. When resizing any portion of the common venting system, the common venting system should be resized to approach the minimum size as determined using the appropriate tables in Part II in the *National Fuel Gas Code*, NFPA 54/ANSI Z223.1.

B. VENTING

WARNING

Improper venting may result in property damage and the release of flue gases which contain deadly carbon monoxide (CO) into the building, which can cause severe personal injury and/or death.

1. General Venting Guidelines

In order to properly vent this water heater, the installer must select and install a vent system that meets all requirements specified in this section (VENTING) as well as following the instructions provided by the vent system manufacturer.

- a. The vent system shall be designed and constructed in accordance with the National Fuel Gas Code/ NFPA 54 ANSI Z223.1 and applicable local building codes to develop a positive flow adequate to convey flue or vent gases to the outdoors.
- b. If this water heater is being installed in Massachusetts, follow the Massachusetts Code instructions printed later in this section.
- c. Consult the vent pipe manufacturer's instructions for vent system assembly and system specific installation requirements.
- d. Vent pipe system shall be acceptable for use with water heater fuel type.
- e. Vent pipe system shall be compatible either by directly connecting, or by use of an adapter, to the water heater vent connection.
 - i. This appliance is shipped with an AL 29-4C® Heat-Fab Saf-T-Vent connection.
 - ii. Alteration of the water heater vent connection is prohibited.
- f. Do not reduce the diameter of the vent pipe. The vent pipe must not be smaller than the vent connector on the water heater.

WARNING

Vent pipe system must be made of materials approved for use with condensing flue gases. Covering non-metallic vent pipe and fittings with thermal insulation is prohibited. Use of cellular core PVC (ASTM F891), cellular core CPVC, or Radel® (polyphenylsulfone) in non-metallic venting systems is prohibited.

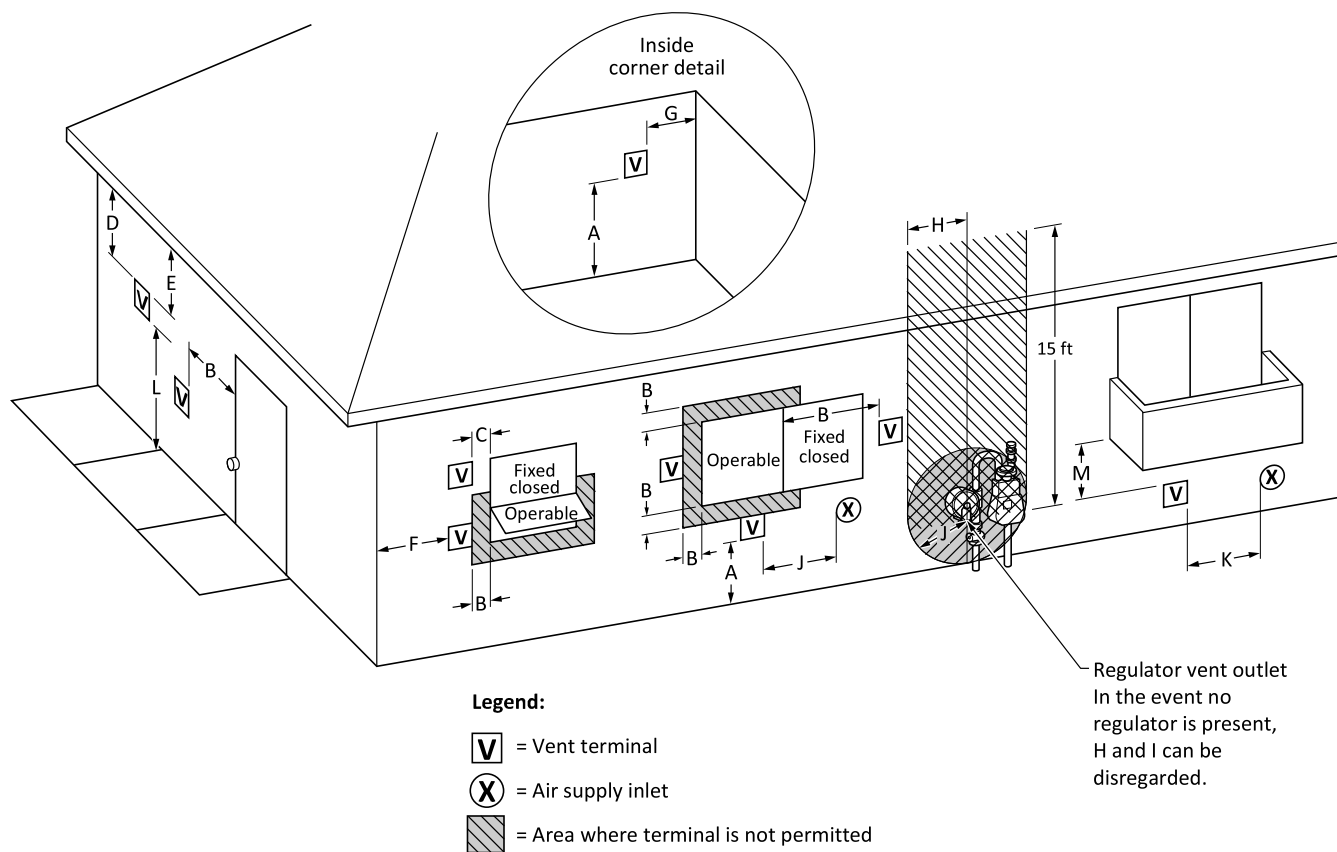

Figure 2: Vent Terminal Clearances

WARNING

The vent for this appliance shall not terminate:

1. Over public walkways; or
2. Near soffit vents or crawl space vents or other areas where condensate or vapor could create a nuisance or hazard or cause property damage; or
3. Where condensate vapor could cause damage or could be detrimental to the operation of regulators, relief valves, or other equipment.

Table 1: Direct Vent Terminal Clearances

		Canadian Installations¹	US Installations²
A	Clearance above grade, veranda, porch, deck, or balcony	12 in (30 cm)	12 in (30 cm)
B	Clearance to window or door that may be opened	6 in (15 cm) for appliances ≤ 10,000 Btuh (3 kW), 12 in (30 cm) for appliances > 10,000 Btuh (3 kW) and ≤ 100,000 Btuh (30 kW), 36 in (91 cm) for appliances >100,000 Btuh (30 kW)	6 in (15 cm) for appliances ≤ 10,000 Btuh (3 kW), 9 in (23 cm) for appliances > 10,000 Btuh (3 kW) and ≤ 50,000 Btuh (15 kW), 12 in (30 cm) for appliances > 50,000 Btuh (15 kW)
C	Clearance to permanently closed window	*	*
D	Vertical clearance to ventilated soffit located above the terminal within a horizontal distance of 2 ft (61 cm) from the center line of the terminal.	*	*
E	Clearance to unventilated soffit	*	*
F	Clearance to outside corner	*	*
G	Clearance to inside corner	*	*
H	Clearance to each side of center line extended above meter/regulator assembly	3 ft (91 cm) within a height of 15 ft (4.6 m)	*
I	Clearance to service regulator vent outlet	3 ft (91 cm)	*
J	Clearance to nonmechanical air supply inlet to building or the combustion air inlet to any other appliance	6 in (15 cm) for appliances ≤ 10,000 Btuh (3 kW), 12 in (30 cm) for appliances > 10,000 Btuh (3 kW) and ≤ 100,000 Btuh (30 kW), 36 in (91 cm) for appliances >100,000 Btuh (30 kW)	6 in (15 cm) for appliances ≤ 10,000 Btuh (3 kW), 9 in (23 cm) for appliances > 10,000 Btuh (3 kW) and ≤ 50,000 Btuh (15 kW), 12 in (30 cm) for appliances > 50,000 Btuh (15 kW)
K	Clearance to a mechanical air supply inlet	6 ft (1.83 m)	3 ft (91 cm) above if within 10 ft (3 m) horizontally
L	Clearance above paved sidewalk or paved driveway located on public property	7 ft (2.13 m) †	7 ft (2.13 m) for mechanical draft systems (Category I appliances). Vents for Category II and IV appliances cannot be located above public walkways or other areas where condensate or vapor can cause a nuisance or hazard*
M	Clearance under veranda, porch deck, or balcony	12 in (30 cm) ‡	*

* Clearance in accordance with local codes and the requirements of the gas supplier.

† A vent shall not terminate directly above a sidewalk or paved driveway that is located between two single family dwellings and serves both dwellings.

‡ Permitted only if veranda, porch, deck, or balcony is fully open on a minimum of two sides beneath the floor.

Notes:

1) In accordance with the current CSA B149.1, Natural Gas and Propane Installation Code

2) In accordance with the current ANSI Z223.1/NFPA 54, National Fuel Gas Code

3) If locally adopted installation codes specify clearances different than those illustrated, then the most stringent clearance shall prevail.

Table 2: Other than Direct Vent Terminal Clearances

		Canadian Installations¹	US Installations²
A	Clearance above grade, veranda, porch, deck, or balcony	12 in (30 cm)	12 in (30 cm)
B	Clearance to window or door that may be opened	6 in (15 cm) for appliances ≤ 10,000 Btuh (3 kW), 12 in (30 cm) for appliances > 10,000 Btuh (3 kW) and ≤ 100,000 Btuh (30 kW), 36 in (91 cm) for appliances >100,000 Btuh (30 kW)	4 ft (1.2 m) below or to side of opening; 1 ft (300 mm) above opening
C	Clearance to permanently closed window	*	*
D	Vertical clearance to ventilated soffit located above the terminal within a horizontal distance of 2 ft (61 cm) from the center line of the terminal.	*	*
E	Clearance to unventilated soffit	*	*
F	Clearance to outside corner	*	*
G	Clearance to inside corner	*	*
H	Clearance to each side of center line extended above meter/regulator assembly	3 ft (91 cm) within a height 15 ft (4.6 m)	*
I	Clearance to service regulator vent outlet	3 ft (91 cm)	*
J	Clearance to nonmechanical air supply inlet to building or the combustion air inlet to any other appliance	6 in (15 cm) for appliances ≤ 10,000 Btuh (3 kW), 12 in (30 cm) for appliances > 10,000 Btuh (3 kW) and ≤ 100,000 Btuh (30 kW), 36 in (91 cm) for appliances >100,000 Btuh (30 kW)	4 ft (1.2 m) below or to side of opening; 1 ft (300 mm) above opening
K	Clearance to a mechanical air supply inlet	6 ft (1.83 m)	3 ft (91 cm) above if within 10 ft (3 m) horizontally
L	Clearance above paved sidewalk or paved driveway located on public property	7 ft (2.13 m) †	7 ft (2.13 m) for mechanical draft systems (Category I appliances). Vents for Category II and IV appliances cannot be located above public walkways or other areas where condensate or vapor can cause a nuisance or hazard
M	Clearance under veranda, porch, deck, or balcony	12 in (30 cm) ‡	*

* Clearance in accordance with local codes and the requirements of the gas supplier.

† A vent shall not terminate directly above a sidewalk or paved driveway that is located between two single family dwellings and serves both dwellings.

‡ Permitted only if veranda, porch, deck, or balcony is fully open on a minimum of two sides beneath the floor.

Notes:

1) In accordance with the current CSA B149.1, Natural Gas and Propane Installation Code

2) In accordance with the current ANSI Z223.1/NFPA 54, National Fuel Gas Code

3) If locally adopted installation codes specify clearances different than those illustrated, then the most stringent clearance shall prevail.

- g. Vent pipe system must be adequately supported at intervals no less than five (5) feet apart. The completed vent system must be rigid and able to withstand impacts without collapse.
 - h. If any point of the vent pipe system is higher than the water heater flue collar, the vent system must have adequate condensate drain loop(s) to prevent condensate from running back into the water heater.
 - i. It is permissible to run vent pipe through a vertical or horizontal chase provided minimum clearances to combustible materials are maintained.
 - j. The minimum clearance to combustible material is six (6) inches, unless otherwise specified by the vent system manufacturer.
 - k. Horizontal vent pipe must slope no less than one (1) inch in four (4) feet of run.
 - l. The vent termination location is restricted as follows:
 - i. Minimum twelve (12) inches above grade plus normally expected snow accumulation or seven (7) feet above grade if located adjacent to public walkways. DO NOT INSTALL over public walkway where local experience indicates condensation or vapor from the water heater creates a nuisance or hazard.
 - ii. Minimum three (3) feet above any forced air inlet located within ten (10) feet of the vent termination.
 - iii. Minimum four (4) feet below, four (4) feet horizontally or one (1) foot above any door, window or gravity air inlet.
 - iv. Minimum four (4) feet horizontally from electric meters, gas meters, regulators and relief valves. This distance may be reduced if equipment is protected from damage due to condensation or vapor by enclosure, overhangs, etc.
 - v. Minimum twelve (12) inches from corners of building.
 - m. Use appropriately designed thimbles when passing through combustible walls or roofs.
 - n. Install fire-stops where vent passes through floors, ceilings or framed walls. The fire-stop must close the opening between the vent pipe and the structure.
 - o. Enclose vent passing through occupied or unoccupied spaces above the water heater with materials having a fire resistance rating at least equal to the rating of the adjoining floor or ceiling. Maintain minimum clearance to combustible materials.
 - p. Locate vent terminal above combustion air intake terminal (if used) and no closer than one (1) foot horizontally.
 - q. Vertical venting requires flashing and a storm collar to prevent moisture from entering the structure.
 - r. Vertical vent termination must be at least two (2) feet plus the expected snow accumulation above roof penetration height.
 - s. This water heater's venting may be Category IV (positive vent pressure, flue condensing) or Category II (non-positive vent pressure, flue condensing), with regards to National Fuel Gas Code/NFPA 54 ANSI Z223.1.
2. Positive Pressure Venting Requirements
- a. Vent pipe system must be fully sealed.
- WARNING**

Do not use vent dampers or barometric dampers with positive pressure vent systems.
- b. Direct vent applications: For direct vent (ducted combustion air) installations, the maximum vent length is 50 equivalent feet. The vent length is equal to the total length of straight pipe plus the equivalent length of vent fittings.
 - c. Non-direct vent applications: For non-direct vent installations (those without ducted combustion air), design the vent system so that the pressure measured at the outlet of the water heater is between 0"w.c. and 0.3"w.c. at high fire.
 - d. For sidewall venting, slope pipe toward vent termination, if possible.
 - e. See Figure 4, Figure 5, and Figure 6 for positive pressure venting arrangements.
3. Negative Pressure (Conventional) Venting Requirements
- This section outlines requirements for conventional venting installations, where a negative pressure at the water heater flue outlet is achieved by means of natural convection through a vertical length of vent pipe or lined chimney.
- a. Refer to Figure 3 for an example of a typical conventional venting arrangement.
 - b. A lined chimney or vertical length of vent pipe may be used. Chimney lining must be acceptable for use with condensing flue gas.

- c. The minimum chimney/vertical vent height is 15 feet.
- d. Install a condensate drain to collect any condensate that may form in the lined chimney/vertical vent.
- e. Install a double acting barometric damper with integral flue spillage interlock.
- f. The chimney/vertical vent and flue connector must be sized and configured to provide a minimum - 0.04 inch w.c. pressure (draft) at the water heater flue outlet.
- g. The chimney must be protected from down drafts, rain and debris by using a chimney cap or star.
- h. Start installing vent at vent cap and continue installation toward the water heater.
- i. The flue connector and chimney flue diameter may need to be increased or decreased depending on the dimensions of the water heater. Consult the National Fuel Gas Code or Local Codes for sizing. Water heater input, flue connector lateral distance and chimney height affect the flue connector or chimney flue diameters.
- j. A double acting barometric damper with integral flue spillage interlock switch must be used when the water heater is vented conventionally.

4. General Guidelines

- a. This water heater has been certified with AL29-4C® venting. Select a vent material that is approved for use with condensing flue gases.
- b. Install vent system before installing air intake, water, gas or electrical connections.
- c. For instances where the vent system manufacturer's instructions do not make a specification, refer to the below points.
 - i. Make sure pipe and fittings are clean by swabbing with alcohol. Use Dow Corning 736 or 732 RTV, Polybar #500 RTV or Sil-bond 4500 or 6500 to seal vent pipe.
 - ii. Refer to the appropriate drawings in this section of this manual to determine common acceptable configurations of venting system.

5. IMPORTANT

The Commonwealth of Massachusetts requires compliance with regulation 248 CMR 4.00 and 5.00 for installation of side-wall vented gas appliances as follows:

For all side wall horizontally vented gas fueled equipment installed in every dwelling, building or structure used in whole or in part for residential purposes, including those owned or operated by the Commonwealth and where the side wall exhaust vent termination is less than seven (7) feet above finished grade in the area of the venting, including but not limited to decks and porches, the following requirements shall be satisfied:

- a. **INSTALLATION OF CARBON MONOXIDE DETECTORS.** At the time of installation of the side wall horizontal vented gas fueled equipment, the installing plumber or gasfitter shall observe that a hard wired carbon monoxide detector with an alarm and battery back-up is installed on the floor level where the gas equipment is to be installed. In addition, the installing plumber or gasfitter shall observe that a battery operated or hard wired carbon monoxide detector with an alarm is installed on each additional level of the dwelling, building or structure served by the side wall horizontal vented gas fueled equipment. It shall be the responsibility of the property owner to secure the services of qualified licensed professionals for the installation of hard wired carbon monoxide detectors.
 - i. In the event that the side wall horizontally vented gas fueled equipment is installed in a crawl space or an attic, the hard wired carbon monoxide detector with alarm and battery back-up may be installed on the next adjacent floor level.
 - ii. In the event that the requirements of this subdivision can not be met at the time of completion of installation, the owner shall have a period of thirty (30) days to comply with the above requirements; provided, however, that during said thirty (30) day period, a battery operated carbon monoxide detector with an alarm shall be installed.
- b. **APPROVED CARBON MONOXIDE DETECTORS.** Each carbon monoxide detector as required in accordance with the above provisions shall comply with NFPA 720 and be ANSI/UL 2034 listed and IAS certified.
- c. **SIGNAGE.** A metal or plastic identification plate shall be permanently mounted to the exterior of the building at a minimum height of eight (8) feet above grade directly in line with the exhaust vent terminal for the horizontally vented gas fueled heating appliance or equipment. The sign shall read, in print size no less than one-half (1/2) inch in size, "GAS VENT DIRECTLY BELOW. KEEP CLEAR OF ALL OBSTRUCTIONS".

- d. Product Approved side wall horizontally vented gas fueled equipment installed in a room or structure separate from the dwelling, building or structure

MANUFACTURER REQUIREMENTS - GAS EQUIPMENT VENTING SYSTEM PROVIDED. When the manufacturer of Product Approved side wall horizontally vented gas equipment provides a venting system design or venting system components with the equipment, the instructions provided by the manufacturer for installation of the equipment and the venting system shall include:

- e. **INSPECTION.** The state or local gas inspector of the side wall horizontally vented gas fueled equipment shall not approve the installation unless, upon inspection, the inspector observes carbon monoxide detectors and signage installed in accordance with the provisions of 248 CMR 5.08(2)(a)1 through 4.

EXEMPTIONS: The following equipment is exempt from 248 CMR 5.08(2)(a)1 through 4:

- f. The equipment listed in Chapter 10 entitled "Equipment Not Required To Be Vented" in the most current edition of NFPA 54 as adopted by the Board; and

- g. Detailed instructions for the installation of the venting system design or the venting system components; and
- h. A complete parts list for the venting system design or venting system.

MANUFACTURER REQUIREMENTS - GAS EQUIPMENT VENTING SYSTEM NOT PROVIDED. When the manufacturer of a Product Approved side wall horizontally vented gas fueled equipment does not provide the parts for venting the flue gases, but identifies "special venting systems", the following requirements shall be satisfied by the manufacturer:

- i. The referenced "special venting system" instructions shall be included with the appliance or equipment installation instructions; and
- j. The "special venting systems" shall be Product Approved by the Board, and the instructions for that system shall include a parts list and detailed installation instructions.

A copy of all installation instructions for all Product Approved side wall horizontally vented gas fueled equipment, all venting instructions, all parts lists for venting instructions, and/or all venting design instructions shall remain with the appliance or equipment at the completion of the installation.

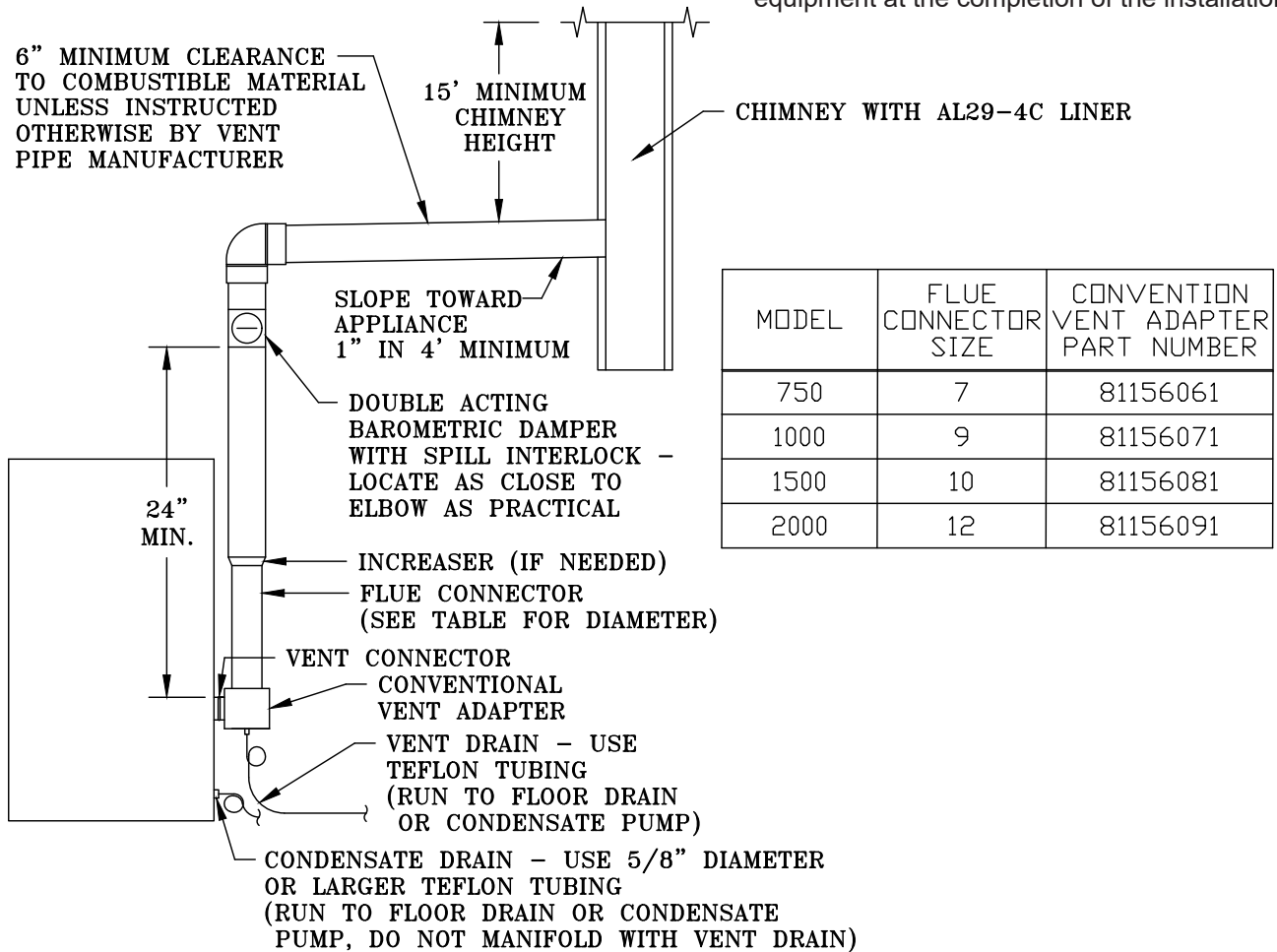

Figure 3: Typical Negative Pressure (Conventional) Venting

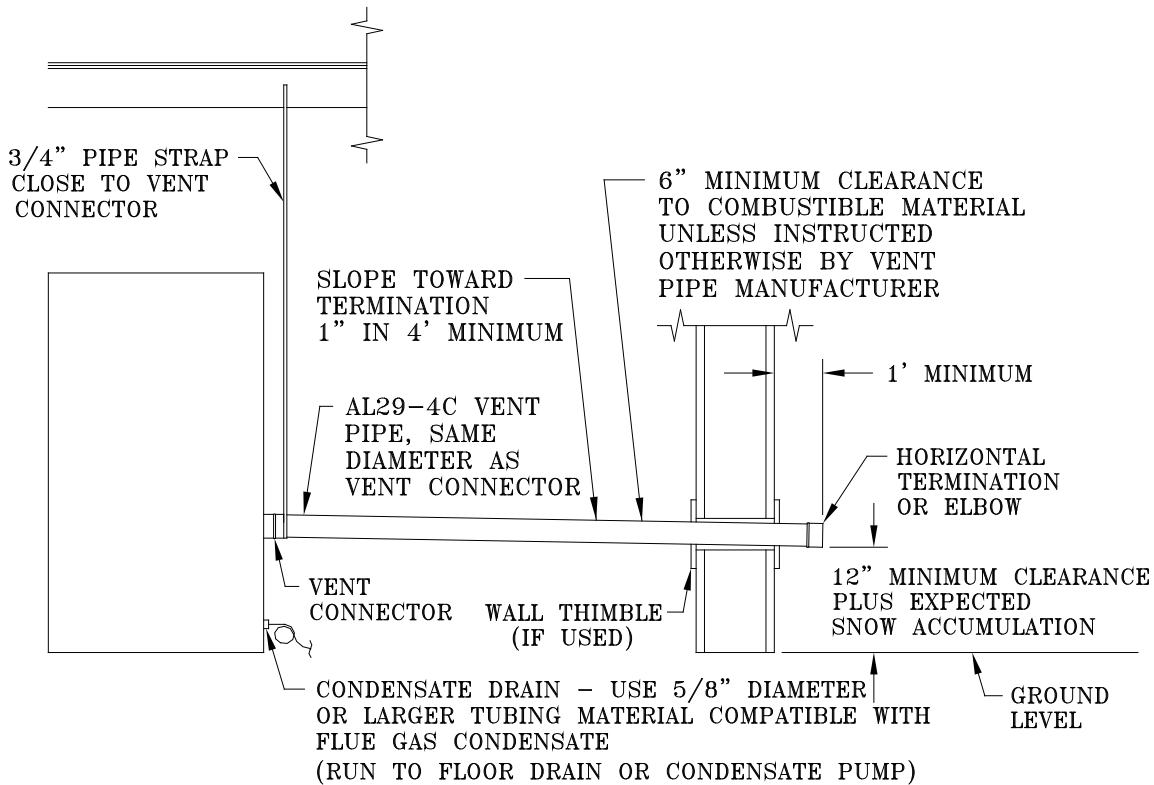

Figure 4: Sidewall Positive Pressure Venting

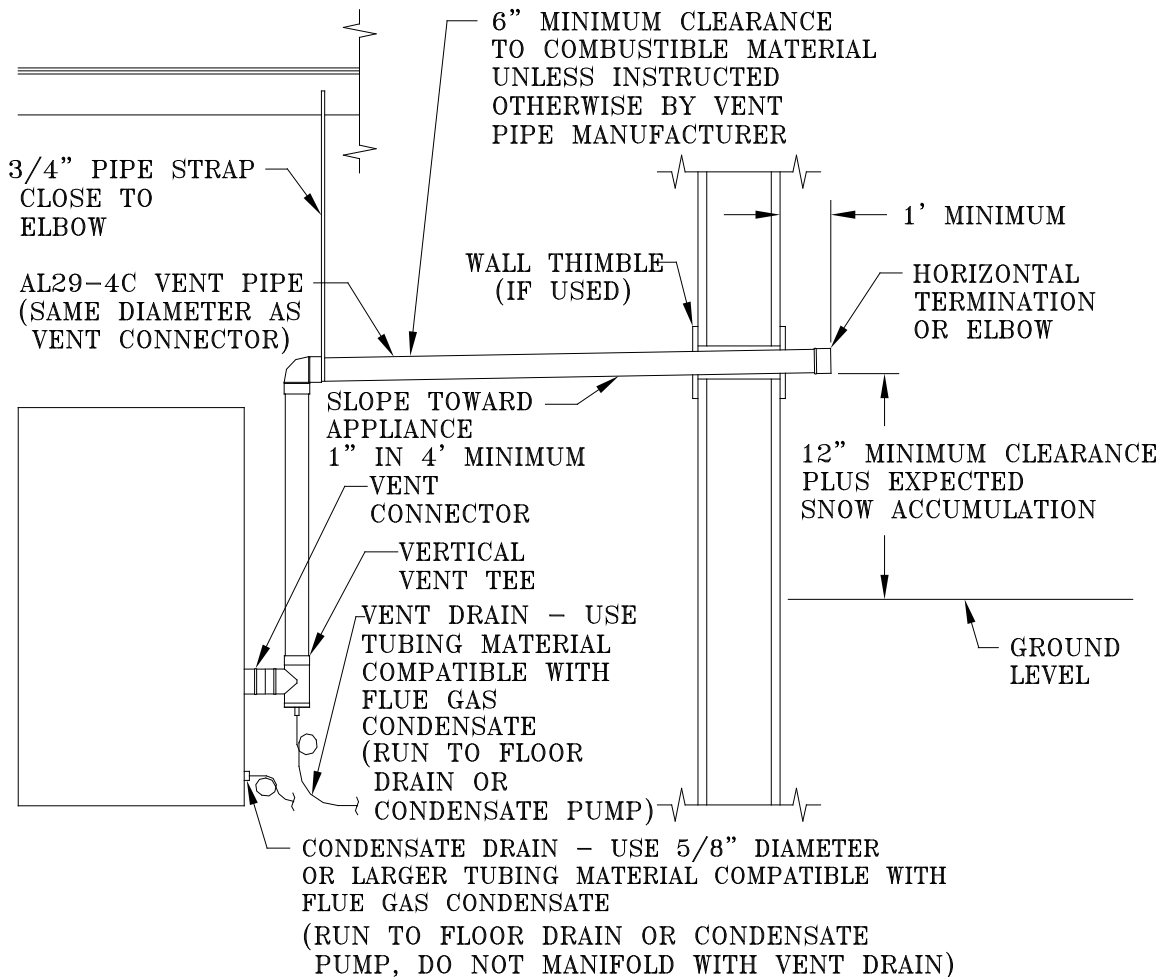

Figure 5: Sidewall Positive Pressure venting (Optional)

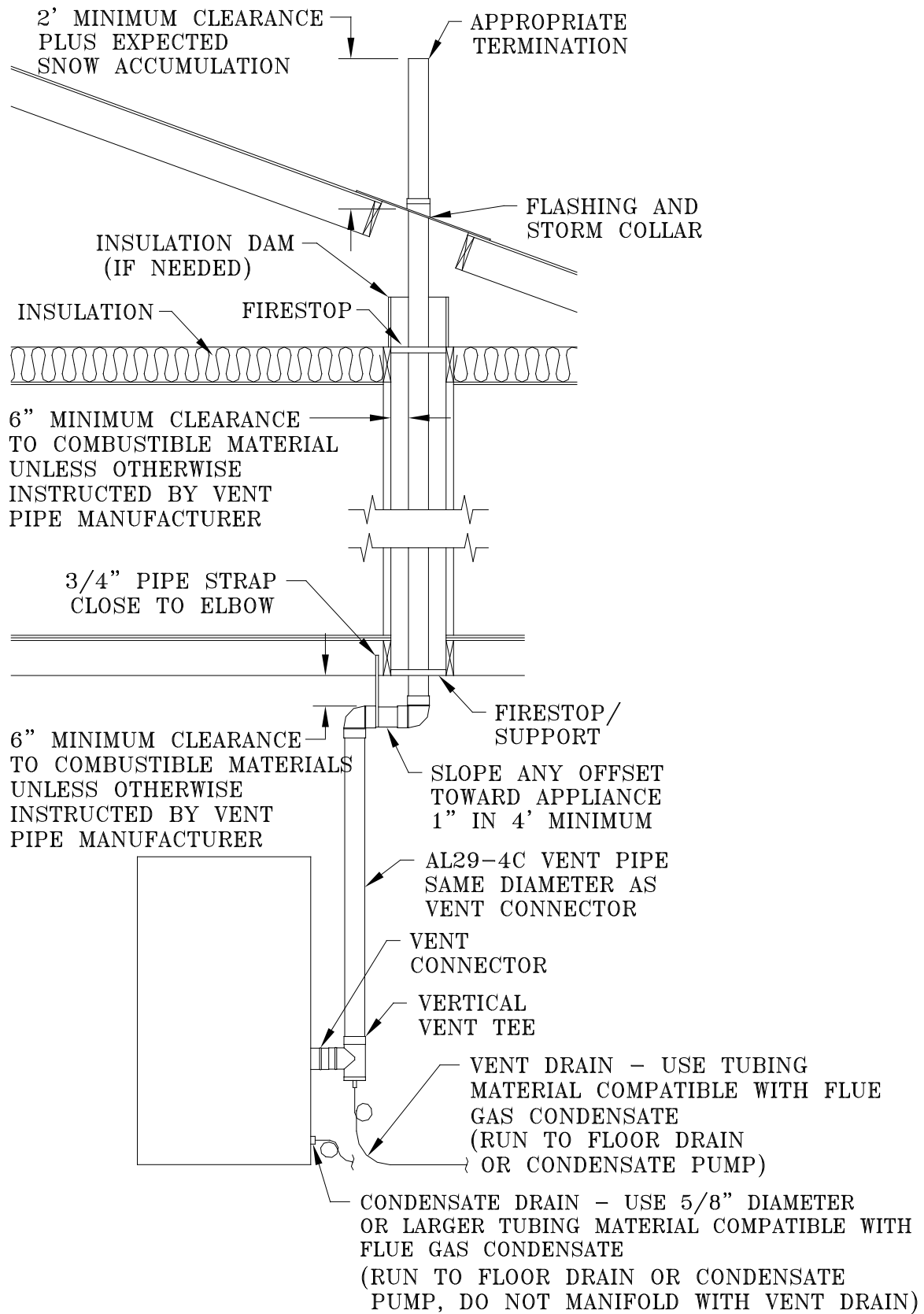

Figure 6: Vertical Pressurized Venting

C. COMBUSTION AIR

1. The water heater may be operated with inside or outside air.
2. Refer to combustion air piping drawings in this section of this manual for proper outside air installation details.
3. Combustion air conduit can be galvanized smoke pipe, PVC, CPVC, or flexible aluminum conduit.
4. The maximum air inlet length is fifty (50) equivalent feet. Air inlet length is equal to the total length of straight pipe plus the equivalent length of fittings. Consult conduit manufacturer for equivalent length of fittings and pipe.
Consult factory for inlet lengths in excess of 50 feet.
5. All joints and seams of the air intake pipe must be sealed using Silicone caulk, such as RTV 732 or equivalent.
6. Air intake termination must be located at least twelve (12) inches above grade plus the expected snow accumulation.

7. Water heater may be installed with vertical venting and sidewall combustion air inlet or visa versa.
8. The air intake pipe must be adequately supported with straps or supports no less than five (5) feet apart. The completed air intake pipe system must be rigid and able to withstand impacts without collapse.

CAUTION

Dirty, contaminated or dusty air used for combustion will decrease the useful life of the water heater air filter. Use outside air if inside air quality is questionable. Use outside air if the water heater is installed in manufacturing plants, laundries, dry cleaners or other locations with heavy particulates in the air.

WARNING

Do not locate air intake where petroleum distillates, CFC's, detergents, volatile vapors or any other chemicals are present. Severe water heater corrosion and failure will result. Thermal Solutions does not warrant failures caused by contaminated air.

Do not locate air intake termination where natural convection or wind conditions may cause the water heater exhaust gases to be drawn into the air intake.

WARNING

Do not reduce size of air intake pipe.
Read, understand and follow combustion air instruction restrictions contained in the Pre-Installation instructions of this manual.

ALL EXPOSED AIR INTAKE PIPING MUST BE CONSTRUCTED OF CORROSION RESISTANT MATERIAL SUCH AS ALUMINUM, STAINLESS STEEL OR PVC

DO NOT LOCATE CENTERLINE OF VENT TERMINAL BELOW CENTERLINE OF AIR INTAKE WALL PENETRATION

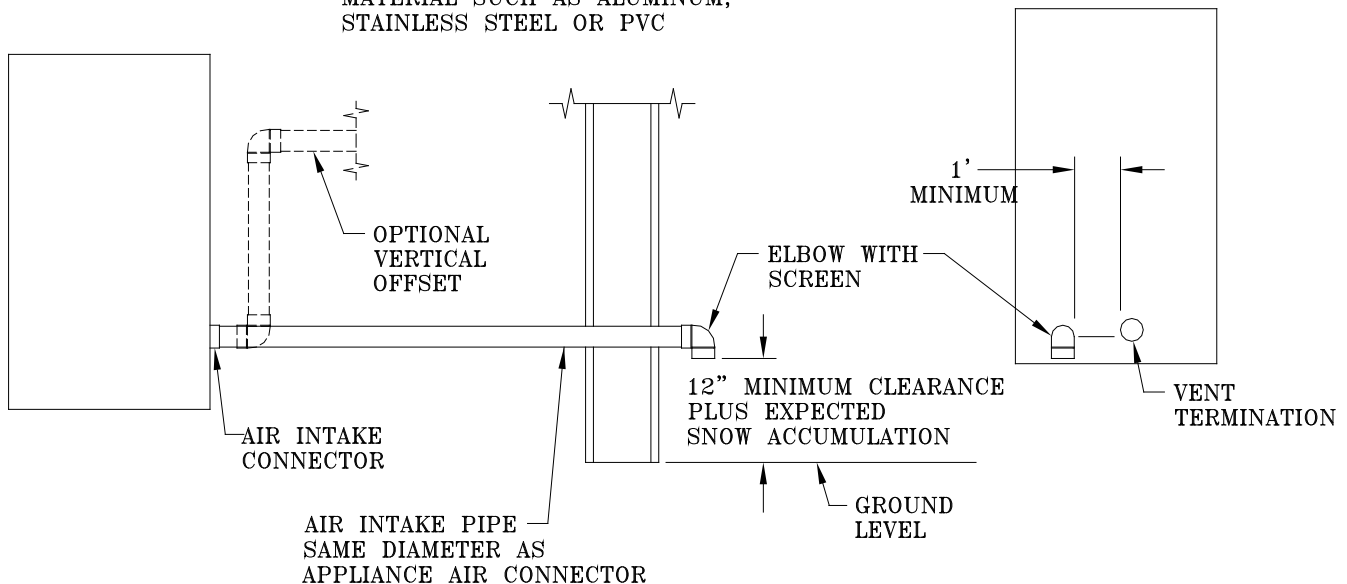

Figure 7: Horizontal Air Intake Piping

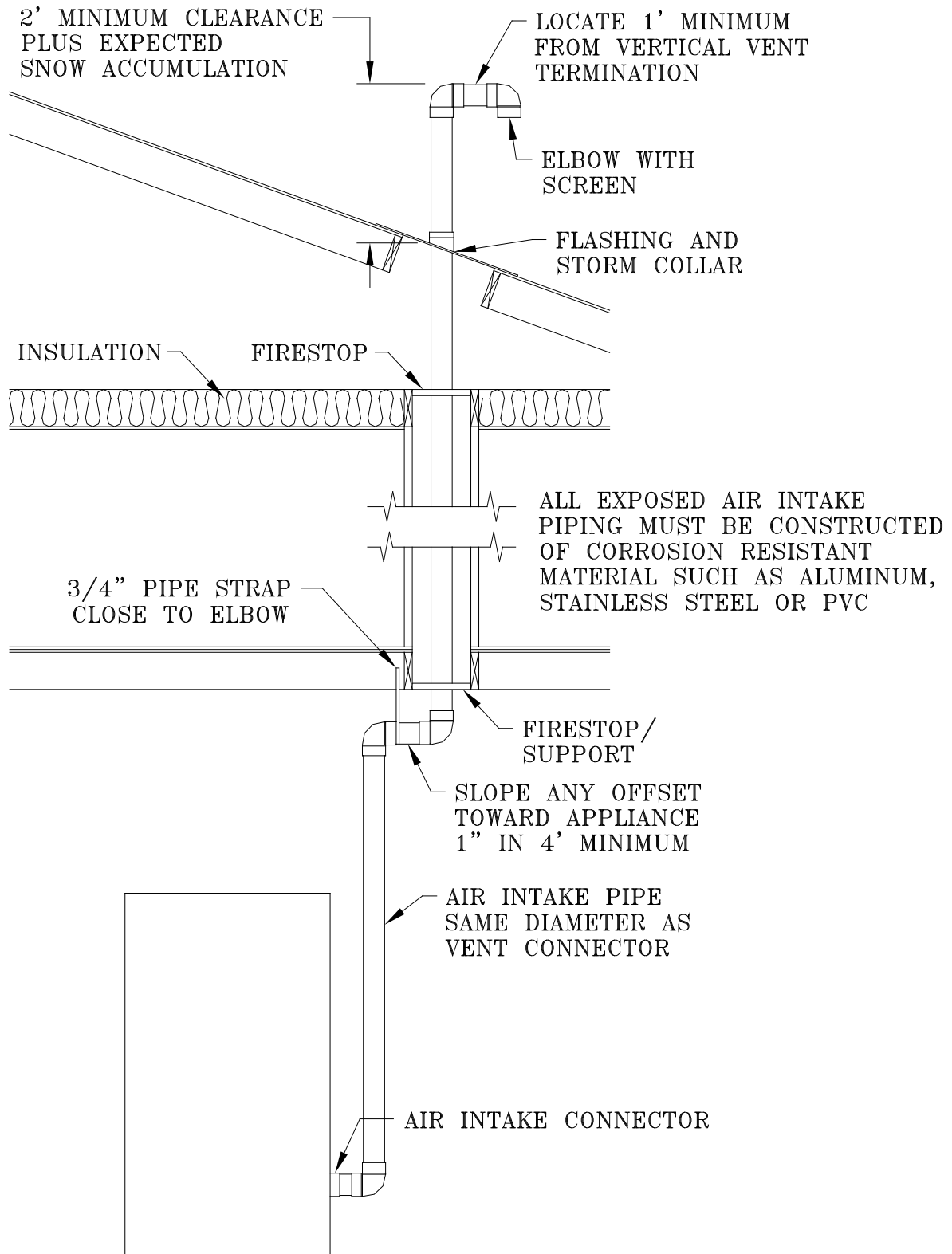

Figure 8: Vertical Air Intake Piping

D. VENTING MATERIALS

1. Vent/combustion air system materials that are approved for use with this appliance are listed in Table 3. Venting manufacturers not listed in this manual may be acceptable. It is the responsibility of the installer or vent supplier to use compatible adapters and materials.
 - a. It is recommended to consult with venting professionals and designers when determining the vent system for this appliance.

Table 3: Approved Vent Manufacturers and Materials

Make	Material	Model	Standard
Heat Fab	Stainless Steel	Saf-T Vent EZ Seal*	UL 738, ULC S636
Z-Flex (Nova Flex Group)	Stainless Steel	Z-Vent	
DuraVent	Stainless Steel	FasNSeal	

*Factory supplied flue connection. Adapters are required to transition to alternate vent materials or manufacturers.

Table 4: Vent Adapters

Vent Diameter (in.)	Adapt to Z-Flex Z-Vent	Adapt to Duravent FasNSeal
4	2SVSHF04	FSA-HFA4
6	2SVSHF06	FSA-HFA6
8	2SVSHF08	FSA-HFA8
10	2SVSHF10	FSA-HFA10

Table 5: Vent Terminations

Model	Vent Diameter (in.)	Style	Heat Fab Part # Saf-T Vent	Z-Flex Part # Z-Vent	Duravent Part # FasNSeal
EVO-750 EVO-1000	6	Tee	9690TEE	2SVST06	FSTT6
		Elbow	9614TERM	2SVEE0690	
		Straight	9692	2SVSTPX06	FSBS6
EVO-1500 EVO-2000	8	Tee	9890TEE	2SVST08	
		Elbow	9814TERM	2SVEE0890	
		Straight	9892	2SVSTPX08	FSBS8

NOTICE

For Category II, III and IV water heaters, the venting system shall be installed in accordance with the water heater manufacturer's instructions and, if applicable, the venting system manufacturer's instructions. This appliance's vent system must be installed with means for condensate disposal.

E. WATER TREATMENT

The quality of water used in the system is essential for the successful operation and longevity of the system components. A successful water treatment plan will help to maintain efficiency, reduce the regularity of repair and/or replacement, and extend the working life of the water heater and other system equipment. If left untreated, poor water quality could cause a number of problems including, but not limited to, oxidation, scaling, corrosion, and fouling. See Table 6 for examples of typical chemical agents found in untreated water along with their potential effects.

Table 6: Chemical Agents and Effects

Compound	Effect
Calcium Carbonate (CaCO ₃)	Soft Scale
Calcium Bicarbonate (CaHCO ₃)	Soft Scale, CO ₂
Calcium Sulphate (CaSO ₄)	Hard Scale
Calcium Chloride (CaCl ₂)	Corrosion
Magnesium Carbonate (MgCO ₃)	Soft Scale
Magnesium Bicarbonate (MgHCO ₃)	Corrosion, Scale
Magnesium Sulphate (MgSO ₄)	Corrosion
Silicon Dioxide (SiO ₂)	Hard Scale

Since the condition of water varies from location to location, it is impossible to prescribe a one-size-fits-all treatment plan for the system water. In order to develop an effective water treatment plan, it will be necessary to gain knowledge of the impurities dissolved in the water. Once all the impurities are identified, the proper treatment plan can be established. Therefore, it will be essential to obtain the expertise of a qualified industrial water treatment professional for establishing a treatment plan.

In addition, a periodic testing/sampling plan should be developed. The intent of the plan should be to: (1) ensure the protection of the water heater and system equipment, (2) prevent an unforeseen system failure, (3) provide information for use in addressing the water quality, and (4) to confirm the proper concentration of chemicals in use.

CAUTION

The system water shall have a maximum water hardness of 8.5 grains or 150 ppm. However, other aspects of water quality can affect system operation and longevity. A qualified water treatment expert should be consulted to develop a complete water treatment plan.

Oxygen contamination of system water will cause corrosion of iron and steel system components, and can lead to failure. Thermal Solutions Standard Warranty does not cover problems caused by oxygen contamination of system water.

Proper water treatment and water heater maintenance is required to avoid scale build-up on the inside of the water heater. Thermal Solutions Standard Warranty does not cover problems caused by scale build-up.

F. WATER PIPING AND TRIM

CAUTION

Failure to properly pipe water heater may result in improper operation and damage to the water heater structure.

Proper water treatment is required. The water shall have a maximum water hardness of 8.5 grains or 150 ppm. The recommended pH range is 8.8 to 9.2.

Oxygen contamination of water heater water can lead to failure. Thermal Solutions Standard Warranty does not cover problems caused by oxygen contamination of water heater water or scale (lime) build-up.

On an existing or retrofit system, a filter or strainer must be installed on the system return prior to the water heater.

1. Design and install water heater and system piping to prevent oxygen contamination of appliance water and frequent water additions.
 - a. There are many possible causes of oxygen contamination such as:
 - i.* Addition of excessive make-up water as a result of system leaks.
 - ii.* Absorption through open tanks and fittings.
 - iii.* Oxygen permeable materials in the distribution system.
 - b. In order to insure long product life, oxygen sources must be eliminated. This can be accomplished by taking the following measures:
 - i.* Repairing system leaks to eliminate the need for addition of make-up water.
 - ii.* Eliminating and/or repairing fittings which allow oxygen absorption.
 - iii.* Using of non-permeable materials in the distribution system.
 - iv.* Isolating the water heater from the system water by installing a heat exchanger.
 - vi.* Using properly designed and operating air elimination devices in water piping.

2. Design and install system piping to prevent return water temperatures below 130°F. Refer to Table 7 for water flow and pressure drop requirements.
3. Connect system supply and return piping to water heater. Refer to Figure 9. Also consult I=B=R Installation and Piping Guides. Maintain ½" minimum distance between water piping and combustible material. Consult Thermal Solutions for unusual system requirements.

CAUTION

Return water temperature below 130°F will cause flue gas condensation inside the water heater. Flue gas condensate can lead to water heater failure. Thermal Solutions Standard Warranty Does not cover problems caused by flue gas condensation.

WARNING

Supply and return water temperature differences greater than 40°F at high fire can lead to water heater failure. Thermal Solutions Standard Warranty does not cover problems caused by temperature difference greater than 40°F at high fire.

4. Install drain valve in fitting provided at bottom rear of the water heater.
5. Install optional low water cut-off such as McDonnell & Miller Model PS851-M-120 or equal in system piping above the water heater.

Table 7: Flow Rates and Pressure Drop

MODEL	20°ΔT (at high fire)		40°ΔT (at high fire)		Minimum Flow Rate (gpm)	Maximum Flow Rate (gpm)	Supply/Return Pipe (inch dia.)
	ΔP (Ft.)	Flow (GPM)	ΔP (Ft.)	Flow (GPM)			
EVO-750	1.81	62	0.46	31	31	62	3
EVO-1000	3.24	82	0.81	41	44	82	3
EVO-1500	7.37	125	1.85	63	63	125	3
EVO-2000	13.27	170	3.32	85	85	170	3

CAUTION

Failure to operate the unit with the proper water flow rate can lead to appliance failure. Always install water flow switch so that the unit stops operating if improper water flow is present.

Safety relief valve discharge piping must be piped such that the potential of severe burns is eliminated. DO NOT pipe in any area where freezing could occur. DO NOT install any shut-off valves, plugs or caps. Consult Local Codes for proper discharge piping arrangement.

Do not operate water heater with flow rates in excess of the maximum flow rates listed. Tube erosion and pitting will occur. Thermal Solutions Standard Warranty does not cover problems caused by excessive water flow rates.

If a high head system pump is installed, assure that the appliance relief valve and system piping are capable of operating properly at the combined pressure of the system fill pressure plus the pump static head pressure. Do not install valves, plugs or caps in safety relief valve piping.

Do not install valves, plugs or caps in safety relief valve piping.

Safety relief valve piping must be terminated such that in the event the safety relief valve opens, the discharge will not cause personal injury or damage.

6. There must be a minimum of five pipe diameters of straight horizontal run downstream of the flow switch. Otherwise, premature failure of flow switch paddle may occur. See flow switch instruction manual (MM-601) included with water heater.
7. If the water heater is installed in a closed water supply system, such as one having a back flow preventer in the cold water supply line, means shall be provided to control thermal expansion. Contact the water supplier or local plumbing inspector on how best to control this situation.
8. A pressure relief valve is supplied with each water heater. No valve is to be placed between the relief valve and appliance. No reducing coupling or other restriction shall be installed in the discharge line.
 - a. Pipe the safety relief discharge to a suitable place for disposal when relief occurs.
 - b. Do not install reducing couplings or other restrictive devices in the safety relief discharge line.
 - c. The safety relief discharge line must allow for complete drainage of both the valve and line.
9. If the relief valve discharges periodically, this may be due to thermal expansion in a closed water supply system. Contact the water supplier or local plumbing inspector on how to correct this situation. **DO NOT PLUG THE RELIEF VALVE.**
10. The separate hot water storage container must have a temperature and pressure relief valve installed.
 - a. This relief valve shall comply with the standard for relief valves for hot water supply systems ANSI Z21.22-CSA4.4.

- b. No reducing coupling or other restriction shall be installed in the discharge line.
- c. No valve shall be placed between the relief valve and tank.

11. The discharge from temperature and pressure valve(s) shall be conducted to a suitable place for disposal when relief occurs.
12. If the appliance is used in an application other than that of a circulating type, a temperature and pressure relief valve must be installed near the hot water outlet.
13. All relief valves shall be installed in a manner such that they are accessible for servicing or replacement.

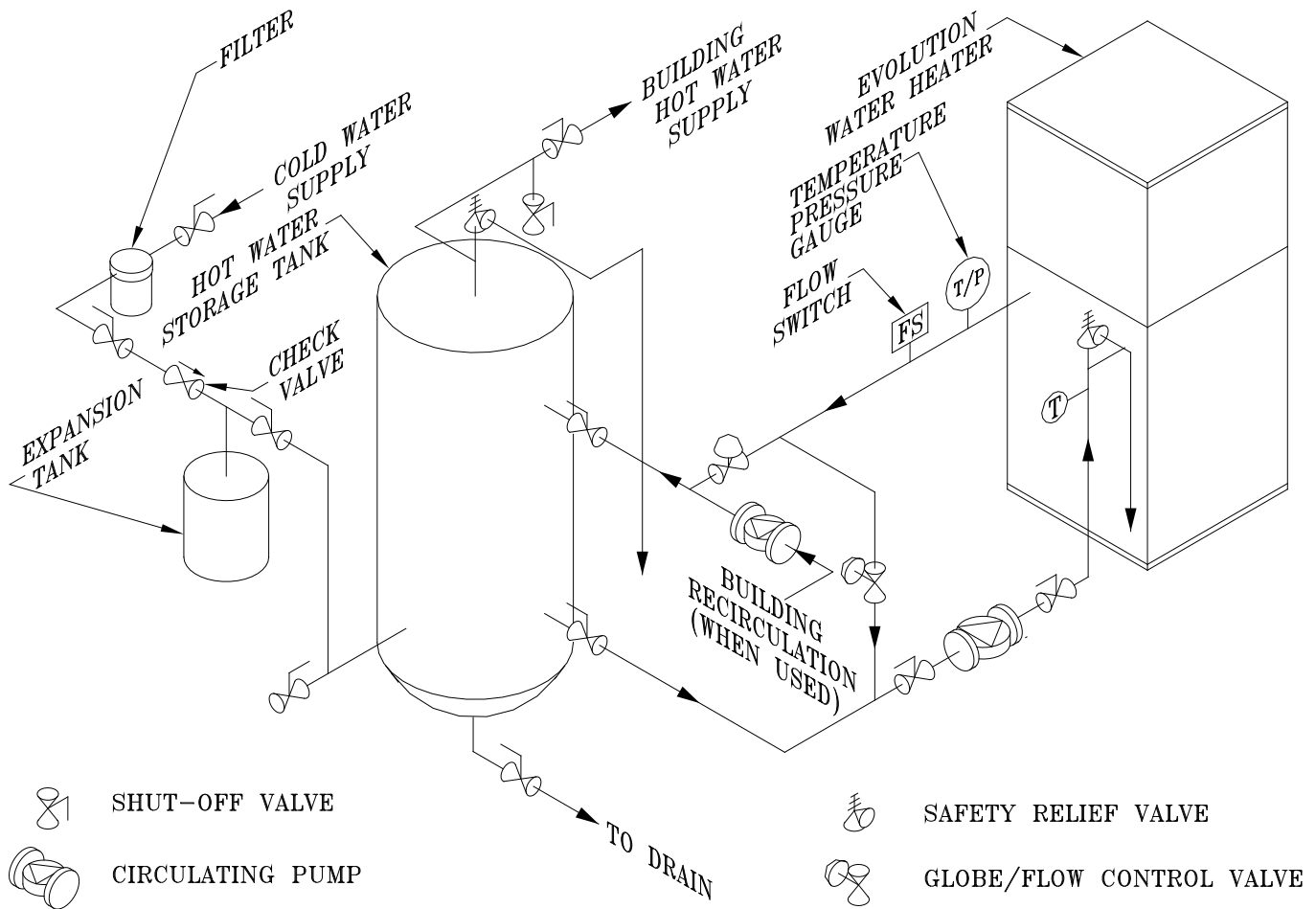

Figure 9: Water Piping

G. GAS PIPING

WARNING

Failure to properly pipe gas supply to water heater may result in improper operation and damage to the appliance or structure. Always assure gas piping is absolutely leak free and of the proper size and type for the connected load. An additional gas pressure regulator may be needed. Consult gas supplier.

1. Size gas piping. Design system to provide adequate gas supply to water heater. Consider these factors.
 - a. Allowable pressure drop from point of delivery to water heater. Refer to Table 8 for minimum and maximum water heater gas train inlet pressure.
 - b. The maximum inlet gas pressure must not exceed the valve specified in Table 8. If gas supply pressure is higher than maximum listed, an additional field supplied pressure regulator will be required.
 - c. The minimum inlet gas pressure listed in Table 8 is to assure an adequate gas supply for water heater operation.
 - d. Maximum gas demand. Table 13 lists water heater input rate. Also consider existing and expected future gas utilization equipment (i.e., heating appliances, cooking equipment, etc).
 - e. Length of piping and number of fittings. Refer to Table 9 for maximum capacity of schedule 40 pipe. Table 12 lists equivalent pipe length for standard fittings. Table 10 lists correction factors for pressure drops other than 0.3 in w.c.

- f. Specific Gravity of Gas. Refer to Table 11 unless an authority having jurisdiction specifies a specific gravity factor to be applied. If the exact specific gravity is not shown, choose next highest value. For gas piping material other than schedule 40 pipe, refer to National Fuel Gas Code, NFPA 54/ANSI Z223. 1 and/or CAN/CGA B149 Installation Codes.

WARNING

Failure to use proper thread compounds on all gas connectors may result in leaks of flammable gas.

2. If step down regulator is required, it must be used in conjunction with the factory supplied regulator and be located as far away from the water heater as possible to prevent nuisance shutdowns.
 - a. The minimum and maximum inlet gas pressure must not exceed the value specified in Table 8.
3. Install field supplied sediment trap, ground-joint union and manual shut-off valve upstream of factory supplied shut-off valve outside the water heater jacket. Use methods and materials in accordance with Local Codes and requirements of gas supplier. In absence of such requirements, follow National Fuel Gas Code, NFPA 54/ANSI Z223.1 and/or CAN/CGA B149 Installation Codes.
4. Use thread joint compound resistant to the action of liquefied petroleum gas.

Table 8: Gas Train Inlet Pressures

Model	MIN. ("w.c.)	MAX.
EVO-750*	7.0	5 psi-NG 2 psi-LP
EVO-1000*	7.0	
EVO-1500*	7.0	
EVO-2000*	9.0	
* Available with optional gas train with min 4" w.c. inlet gas pressure.		

5. All above ground gas piping upstream from field supplied manual gas valve must be electrically continuous and bonded to a grounding electrode. Do not use gas piping as grounding electrode. Refer to National Electrical Code, ANSI/NFPA 70 and /or CSA C22.1 Electrical Codes.

WARNING

Gas supply to water heater and system must be absolutely shut off prior to installing or servicing appliance gas piping.

6. Pressure test. The water heater and its gas connection must be leak tested before placing water heater in operation.
 - a. Protect the appliance gas control valve.
For all testing over $\frac{1}{2}$ psig, the appliance and it's individual shutoff valve must be disconnected from the gas supply piping for testing at $\frac{1}{2}$ psig or less, isolate the water heater from the gas supply piping by closing appliance's individual manual shutoff valve.
 - b. The appliance must be isolated from the gas piping system by closing it's individual manual shutoff valve during any pressure testing at the gas supply piping system at test pressures equal to or less than $\frac{1}{2}$ psi (3.5 kpa).
 - c. The appliance and it's gas connection must be leak tested before placing into operation. Locate leaks using approved combustible gas detector, soap and water, or similar nonflammable solution.

DANGER

Do not use matches, candles, open flames or other ignition source to check for leaks.

Table 9: Maximum Gas Capacity of Schedule 40 Pipe

(Based on Gas Pressure less than 2 psi, pressure drop of 0.3 in w.c. and 0.6 specific gravity.)

Pipe Length in Equivalent Feet	Pipe Size (in.)							
	3/4	1	1-1/4	1-1/2	2	2-1/2	3	4
	Capacity in Cubic Feet of Gas Per Hour							
10	273	514	1060	1580	3050	4860	8580	17500
20	188	353	726	1090	2090	3340	5900	12000
30	151	284	583	873	1680	2680	4740	9660
40	129	243	499	747	1440	2290	4050	8270
50	114	215	442	662	1280	2030	3590	7330
60	104	195	400	600	1160	1840	3260	6640
70	95	179	368	552	1060	1690	3000	6110
80	89	167	343	514	989	1580	2790	5680
90	83	157	322	482	928	1480	2610	5330
100	79	148	304	455	877	1400	2470	5040
125	70	131	269	403	777	1240	2190	4460
150	63	119	244	366	704	1120	1980	4050
175	58	109	224	336	648	1030	1820	3720
200	54	102	209	313	602	960	1700	3460

Table 10: Correction Factors For Gas Pipe

FOR GAS PIPE PRESSURE DROP OTHER THAN 0.3 IN W.C.	
Pressure Drop	Correction Factor
0.1	0.577
0.2	0.815
0.3	1.00
0.5	1.29
1.0	1.83

Table 11: Specific Gravity Correction Factors

Specific Gravity	Correction Factor	Specific Gravity	Correction Factor
0.50	1.10	1.10	0.74
0.55	1.04	1.20	0.71
0.60	1.00	1.30	0.68
0.65	0.96	1.40	0.66
0.70	0.93	1.50	0.63
0.75	0.90	1.60	0.61
0.80	0.87	1.70	0.59
0.90	0.82	1.80	0.58
1.00	0.78	1.90	0.56

Table 12: Equivalent Length of Standard Fittings and Valves

Pipe Size	I.D. Inches	Valves Fully Open (Screwed, Flanged, Welded)			Schedule 40, Screwed Fittings			
		Gate	Globe	Angle	Swing Check	90° Elbow (threaded)	45° Elbow (threaded)	90° Tee, Flow through Branch (threaded)
1/2"	0.622	0.36	17.3	8.65	4.32	1.55	0.73	3.10
3/4"	0.824	0.48	22.9	11.4	5.72	2.06	0.96	4.12
1"	1.049	0.61	29.1	14.6	7.27	2.62	1.22	5.24
1-1/4"	1.380	0.81	38.3	19.1	9.58	3.45	1.61	6.90
1-1/2"	1.610	0.94	44.7	22.4	11.2	4.02	1.88	8.04
2"	2.067	1.21	57.4	28.7	14.4	5.17	2.41	10.3
2-1/2"	2.469	1.44	68.5	34.3	17.1	6.16	2.88	12.3
3"	3.068	1.79	85.2	42.6	21.3	7.67	3.58	15.3
4"	4.026	2.35	112	56	28.0	10.1	4.70	20.2
6"	6.065	3.54	168	84.1	42.1	15.2	7.07	30.4

Equivalent lengths are for standard screwed fittings and for screwed, flanged, or welded valves relative to schedule 40 steel pipe.

WARNING

Listed gas inputs represent sea level to 2000 feet altitude. Reduce gas input four percent (4%) for each additional 1000 feet above sea level.

Table 13: Rated Input

Model	Rated Capacity (CFH)		Gas Connection Size (inch dia.)
	Natural	LP/Propane	
EVO-750	750	300	1-1/2
EVO-1000	1000	400	1-1/2
EVO-1500	1500	600	1-1/2
EVO-2000	2000	800	1-1/2

H. ELECTRICAL

1. General. Install wiring and ground water heater in accordance with authority having jurisdiction or in absence of such requirements National Electrical Code, ANSI/NFPA 70 and/or CSA C22.1 Electrical Code.
2. The appliance, when installed, must be electrically grounded in accordance with local codes or, in the absence of local codes, with the National Electric Code, ANSI/NFPA 70 and/or the CSA C22.21, Canadian Electric Code.

WARNING

Failure to properly wire electrical connections to the water heater may result in serious physical harm. DO NOT ATTACH ADDITIONAL J-Box to back or top of water heater jacket.

DANGER

Positively assure all electrical connections are un-powered before attempting installation or service of electrical components or connections of the water heater or building. Lock out all electrical boxes with padlock once power is turned off.

3. Connect the main power supply and ground from fused disconnect to proper water heater electrical leads located in the junction box at the rear of the water heater. Refer to electrical consumption plate on water heater jacket.
4. Remove factory supplied jumper wire from terminals 4 and 5. Connect field supplied safety limits or devices (low water cut-off, temperature limit etc.) in series using proper terminals provided in water heater electrical cabinet. Refer to wiring diagram supplied with the appliance for wiring information. Refer to Figure 1, for electrical requirements.
5. The following pages contain sample wiring diagrams. Contact Thermal Solutions Representative or visit website (www.thermalsolutions.com) for current wiring options.

WARNING

Electrical power may be supplied from more than one service. Make sure all power is off before attempting any electrical work.

The wiring diagrams contained in this manual are for reference purposes only. Each water heater may be wired differently according to the specifications given to Thermal Solutions at the time the water heater was purchased. Always use the wiring diagram provided with the water heater. If the wiring diagram provided with the water heater is unavailable, STOP all wiring work and contact Thermal Solutions for a replacement diagram.

Do not directly connect low voltage (24 volt, milliamp etc.) controls to this water heater. If low voltage controls are desired, isolating relays must be used.

Never jump out any safety controls.

ATTENTION

Au moment de l'entretien des commandes, étiquetez tous les fils avant débrancher. Des erreurs de câblage peuvent entraîner un fonctionnement inadéquat et dangereux.

6. An as-built wiring diagram is included with every water heater when it ships.
7. Install water heater circulator with a separate fused disconnect switch. Refer to as-built wiring diagram & manufacturer's data for electrical requirements.

CAUTION

Each water heater must be protected with a dedicated properly sized fused disconnect.

Label all wires prior to disconnection when servicing controls. Wiring errors can cause improper operation. Verify proper operation after servicing.

8. Field Wiring to be performed at the time of water heater installation.

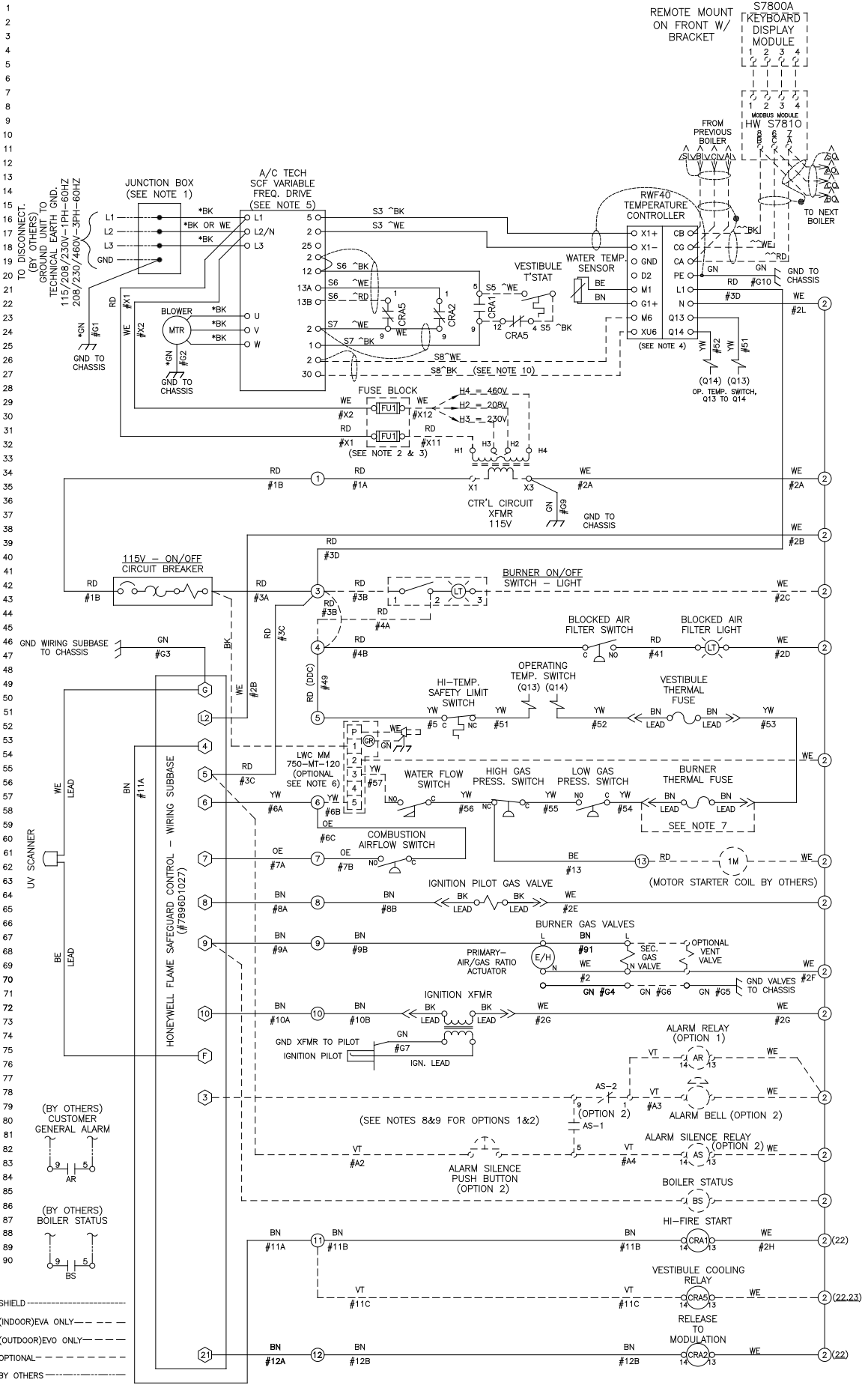

Figure 10: Standard UL/FM/CSD-1 Wiring Diagram (Modulation)

I. MODULAR SYSTEMS

1. General Guidelines

- a. Read and follow all venting, combustion air, water piping, gas piping and electrical instructions contained in this manual unless otherwise instructed in this section.
- b. Modular systems are complex. Design and installation of modular systems should only be undertaken by skilled and knowledgeable engineers and contractors.
- c. Consult Local Building Codes, National Fuel Gas Code, or NFPA 54/ANSI Z222.3 for restrictions and instructions on modular water heater installation.
- d. Refer to the instructions, cautions, notices, and warnings in the General Venting section of this manual.

2. Module Sizing

- a. Consult factory for recommended number and size of water heater for a given input.

3. Venting

- a. Positive Pressure (Sidewall and Vertical) Venting
 - i. Positive pressure vent systems cannot be manifolded together.
 - ii. Positive pressure systems can be piped individually through a common vertical or horizontal chase provided minimum clearances to combustible materials are maintained.
 - iii. Positive pressure systems can be piped individually through a common vertical chase so that a single roof penetration can be made. Each vent termination must be one (1) foot from all other terminations.

- b. Negative Pressure (Conventional) Venting
 - i. Refer to Figure 11 for an example of a typical conventional venting arrangement for modular boilers.
 - ii. Refer to National Fuel Gas Code to determine required chimney diameter and common venting diameter. Note that combined input, lateral length and chimney height affect vent diameter.
 - iii. Install a double acting barometric damper with integral flue spillage interlock (as shown in Figure 11).
 - iv. Locate the appliance(s) with lowest input closest to chimney/vertical common vent.
 - v. Chimney lining must be acceptable for use with condensing flue gases.
 - vi. Install a condensate drain to collect any condensate that may form in the lined chimney or vertical common vent (refer to Figure 11).

CAUTION

DO NOT manifold vent components of multiple appliances without converting to a negative pressure venting arrangement.

CAUTION

Installing multiple vent terminations close together promotes frost build up on buildings. To minimize this possibility, extend the distance from the building to the end of the vent termination and increase the horizontal distance between vent terminations.

4. Air Intake Piping

- a. Consult factory for common air intake pipe sizing
- b. Refer to Figure 12 and Figure 13 for common air intake guidelines for modular water heaters.
- c. Individual air intake pipes may be used in lieu of common air intake piping. If so desired.
- d. The maximum air intake length is fifty (50) equivalent feet. Common air intake straight lengths and fittings should be assumed to have the equivalent length the same as an individual air intake pipe, used for a given water heater intake pipe diameter.

- e. Position horizontal air intake termination center line below horizontal vent termination's center line.
- f. Vertical air intake pipe must terminate at least two (2) feet above the closest portion of the roof.
- g. Refer to the cautions, notices, and warnings in the Combustion Air section of this manual.

NOTICE
Consult factory for common air intake sizing.

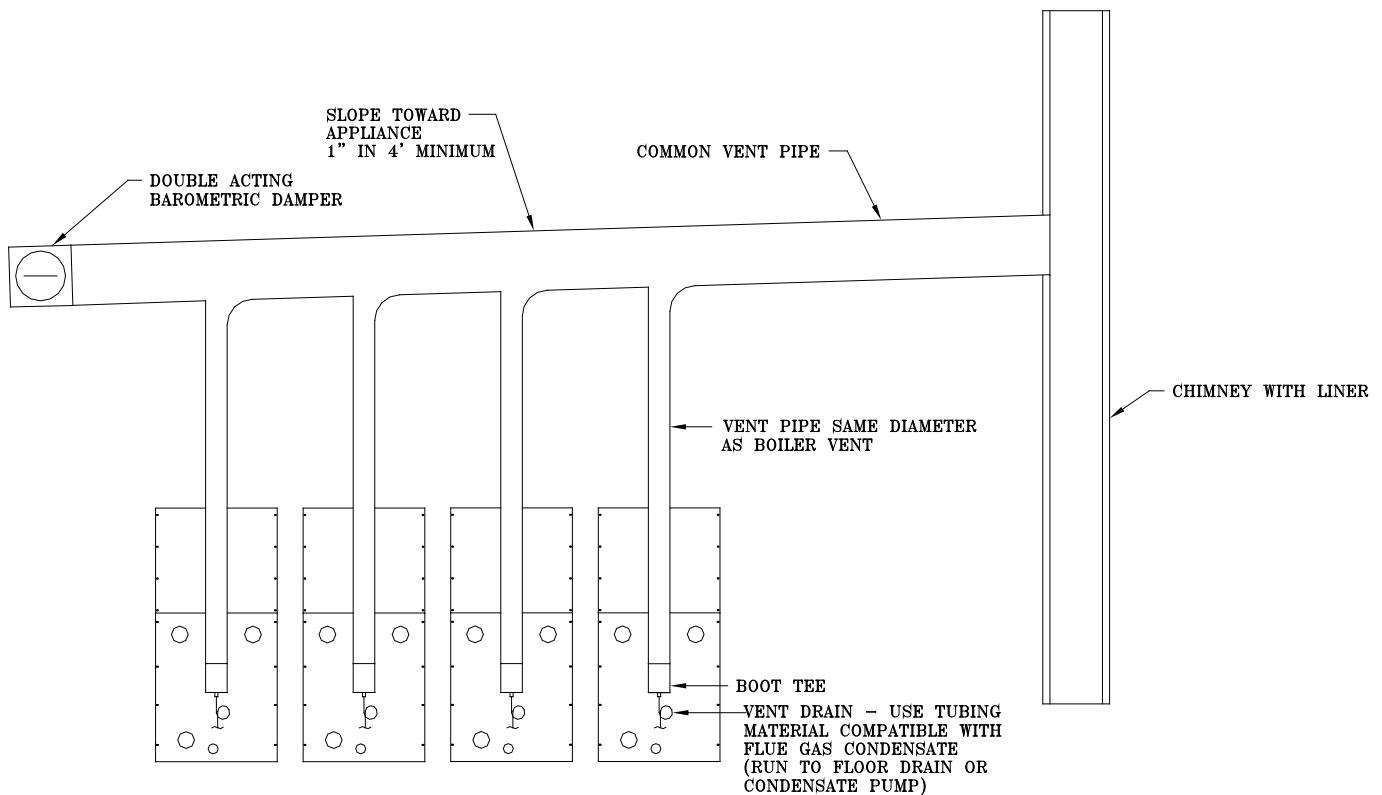

Figure 11: Modular System: Conventional Venting (negative draft)

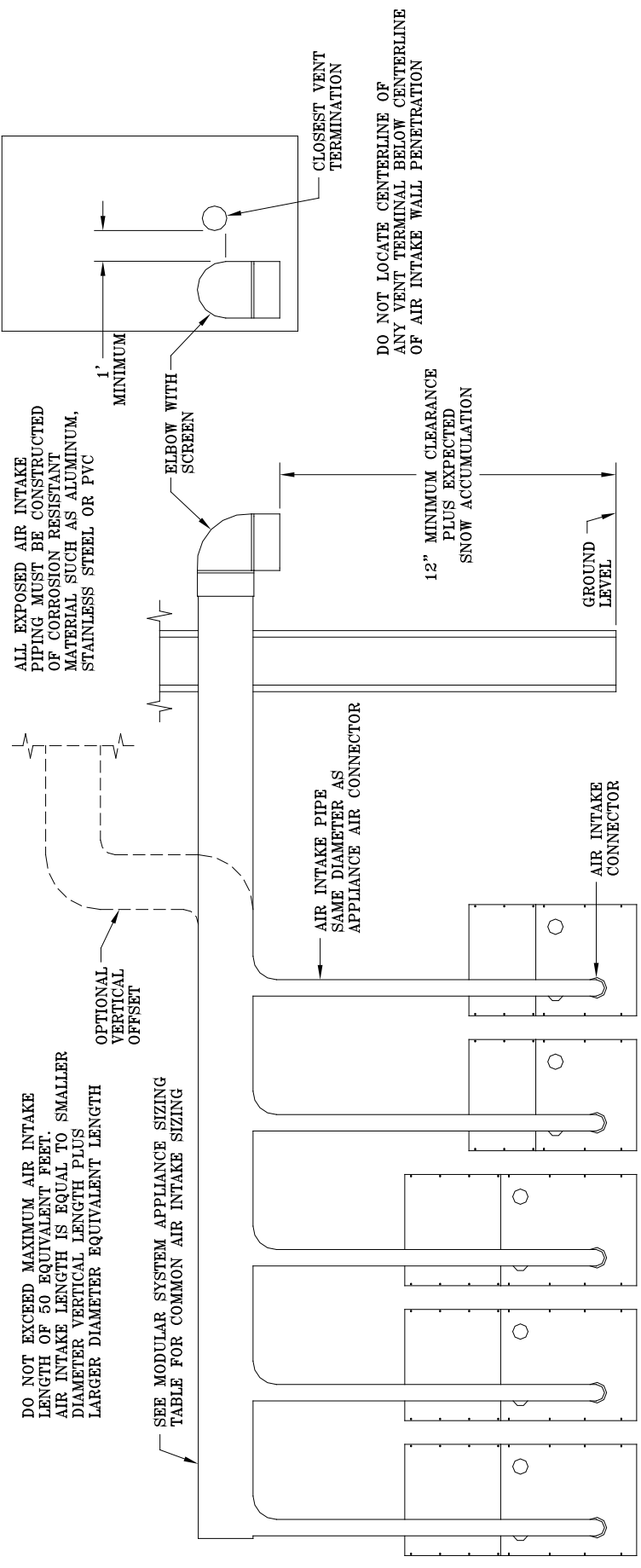

Figure 12: Modular System Horizontal Air Intake Piping

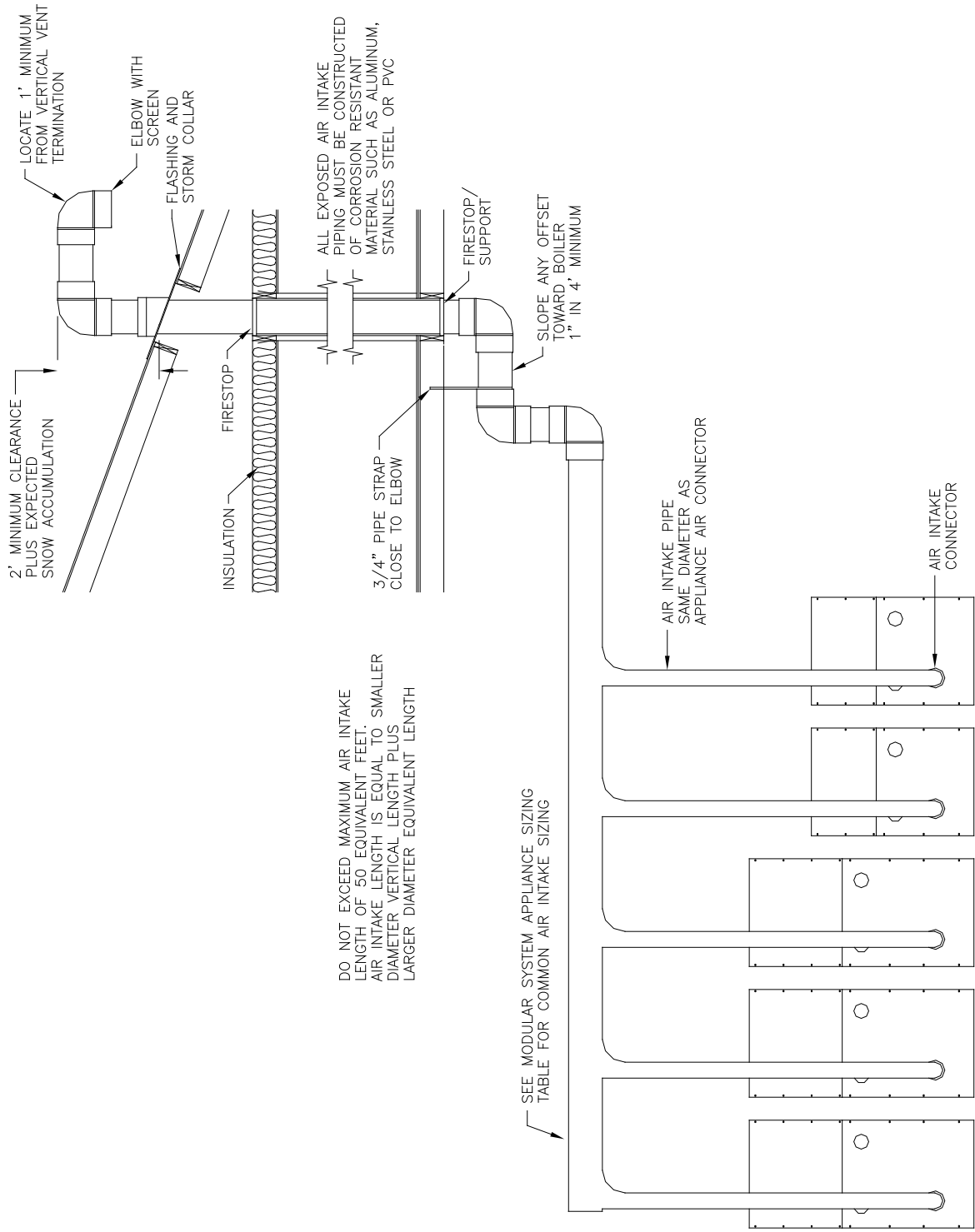

Figure 13: Modular System Vertical Air Intake Piping

5. Water Piping

- a. Refer to Figure 9 for typical water piping for water heaters.
- b. Installing a low water cut-off in the system piping is highly recommended and may be required by Code.
- c. Refer to Table 7 for pressure drop and flow requirements for each water heater.
- d. Refer to the instructions, cautions, notices, and warnings in the Water Piping and Trim Sections of this manual.

NOTICE

The pressure drop given in Table 7 is for the water heater only. The pressure drop of each system fitting and component must be added to the water heater pressure drop to determine the system pressure head requirement. See Table 12 for fitting and component equivalent lengths.

6. Gas Piping

- a. Refer to National Fuel Gas Code, Local Codes and tables in this manual for gas pipe sizing.
- b. Refer to the instructions, cautions, notices, and warnings in the Gas Piping Section of this manual.

WARNING

If gas pressure in the building is above 1/2 psig, for ON/OFF water heaters, an additional gas pressure regulator is required. Use an additional gas pressure regulator for 2 Stage & modulating water heaters, where the gas pressure is greater than 5 psig. Using one additional regulator for multiple water heaters may result in unsafe water heater operation. The additional regulator must be able to properly regulate gas pressure flow at the lowest input of a single water heater. If the regulator cannot do this, two or more additional regulators are required. Consult regulator manufacturer's instructions for minimum gas flow rate.

7. Electrical

- a. Each water heater must be provided with a dedicated fused disconnect.
- b. Install wiring and ground water heater in accordance with requirements of authority having jurisdiction. In absence of such requirements, the National Electrical Code, ANSI/NFPA 70 and/or CSA C22.1 Electrical Code.
- c. Install each circulator with a separate fused disconnect switch. Refer to circulator manufacturer's data for electrical requirements.
- d. Refer to Figure 1 for electrical data for each size appliance.
- e. Refer to the instructions, cautions, notices, and warnings found in the Electrical Section of this manual.

NOTICE

Do not install water heater and circulator pump on the same fused disconnect.

8. Condensate Piping

- a. Each water heater requires separate condensate drains. In addition, most venting configurations require separate condensate drains in the vent system. Do not manifold water heater drains or vent drains together.
- b. Refer to Section H for condensate removal system.

J. CONDENSATE DRAINS

1. Each water heater contains a condensate drain. In addition, most vent configurations require a drain tee located in the vent piping. Pipe each condensate drain separately to a floor drain or condensate pump/sump.
2. Use continuous Teflon or high temperature resistant silicone tubing for condensate piping. Do not install fittings on condensate lines.

CAUTION

Failure to properly pipe condensate system will greatly reduce water heater life. Do not install plugs, caps, or valves on condensate piping. Do not connect condensate drains together. Do not reduce size of condensate piping.

3. Each condensate drain must contain a siphon/pigtail to prevent flue gas flow through the condensate piping.
4. A common condensate pump/sump may be used. Run separate piping from each condensate drain to the sump. A common drain may be used to discharge condensate from the sump. Consult pump/sump manufacturer for compatibility of pump/sump materials of construction. If a common sump is used, individual drain lines should be connected such that one drain cannot back feed into another drain.
5. Consult local authorities regarding disposal of flue gas condensate into public waste water system. Some jurisdictions require that the condensate be buffered before discharge. This buffering is commonly achieved by draining the condensate through a limestone bed. Consult a chemical treatment company for buffering systems.

CAUTION

Do not use material that is not approved for use with flue gas condensate.

IV. System Start-up

CAUTION

Failure to properly pipe water heater may result in improper operation and damage to water heater or structure.

CAUTION

Oxygen contamination of water can lead to water heater failure. Thermal Solutions Standard Warranty does not cover problems caused by oxygen contamination of appliance water or scale (lime) build-up caused by frequent addition of water.

CAUTION

On an existing or retrofit system, a filter or strainer must be installed on the system return prior to the water heater.

- A. Verify that the venting, water piping, gas piping and electrical system are installed properly. Refer to installation instructions contained in this manual.

WARNING

Completely read, understand and follow all instructions in this manual, Honeywell flame safeguard, and all other components manuals supplied with this water heater before attempting start up.

- B. Confirm all electrical, water and gas supplies are turned off at the source and that chimney/vent is clear of obstructions. If the water heater is controlled by an external control system, this system must be temporarily disconnected. The local water heater controls should be allowed to operate the water heater.
- C. Remove the upper front jacket panel.
- D. Confirm that all manual shut-off gas valves between the water heater and gas supply are closed.

CAUTION

This water heater contains a manual gas shut-off valve inside of the upper front jacket panel.

- E. Fill water heater and system with water to desired cold fill pressure. Fully open supply and return water valves and fully close bypass balancing valve.

WARNING

The maximum operating pressure of this water heater is 160 psig. Never exceed this pressure. This water heater was supplied with a safety relief valve with a pressure relief setting specified at the time of purchase. The relief valve setting must be above the maximum operating pressure of the system. Consult Thermal Solutions if the desired system operating pressure is above the safety relief valve pressure setting. Do not plug or change safety relief valve.

- F. Confirm that the water heater and system have no water leaks.
- G. Turn on electrical supply to the water heater and circulation system at fused disconnect switches. Note that there is electrical power at certain components even with the power switch off. See wiring diagram Figure 10.
- H. Turn system circulator on and purge air from the water heater and system piping.
- I. Confirm that water flow switch is operating properly.
- J. Turn on gas supply to the water heater gas piping.
- K. Confirm that the supply pressure to the gas regulator supplied with the water heater conforms to Table 8 for maximum and minimum supply pressures.
- L. Open the manual gas shut-off valves located upstream of the gas regulator supplied with the water heater. Do not open manual gas valve inside of water heater jacket.

DANGER

Do not use matches, candles, open flames or other ignition source to check for leaks.

- M.** Using soap solution, or similar non-combustible solution, electronic leak detector or other approved method, check that included gas piping valves, regulators and all other components are leak free. Eliminate any leaks.
- N.** Purge gas line of air.
- O.** Reset low gas pressure safety switch.
- P.** Turn on control circuit breaker inside front jacket panel. Note that the flame safeguard is powered even with the power switch off.
- Q.** Turn water heater operating switch to the on position.
- R.** Allow water heater to complete pre-purge and trial for ignition period. Once pilot flame is recognized by controller, position flame control switch to test position.
- S.** Look through the water heater sight glass and confirm that pilot flame is blue and steady and that the flame signal is between 1.5 and 5.0 volts DC. Adjust pilot gas regulator until proper pilot manifold gas pressure is achieved per firetest report label. Pilot flame should be blue with very little yellow.
- T.** Turn the water heater off, place flame control switch in "run" position, and repeat Steps R., and S. at least five times until reliable pilot ignition and signal is achieved and confirmed.
- U.** With the pilot operating properly, allow water heater to continue to trial for main flame. Confirm that the flame control locks out on main flame failure.
- V.** Open the manual main gas shut-off valve located inside the water heater jacket.
- W.** Using the procedure detailed in Step M, leak test gas piping and valves inside of jacket. Eliminate any leaks.
- X.** Reset flame safeguard and allow water heater to run through pre-purge, trial for pilot and trial for main flame.
- Y.** Confirm that main flame ignites smoothly. Observe main flame and confirm that burner element is evenly orange without flickering. Observe flame signal and confirm signal is between 1.5 and 5.0 volts DC.

- Z.** Turn water heater off and repeat Steps X and Y at least five times to confirm proper main burner operation.

- AA.** With main flame on, at high fire and low fire, measure gas pressure downstream of the main gas valves and adjust to the manifold pressure indicated on the factory firetest label.

WARNING

Failure to properly adjust gas input rate will result in over firing or under firing of the appliance. Improper and unsafe water heater operation may result.

- BB.** Confirm that high and low gas pressure switches are functioning and are adjusted to prevent over firing or under firing of the water heater.
- CC.** Adjust setting of air filter flow switch by rotating knob on switch counter clockwise until change filter light switch is illuminated. Turn switch knob clockwise $\frac{1}{4}$ turn past the point where the change filter light goes out. Replace upper front jacket panel.
- DD.** With water heater running and all panels attached, measure oxygen (O_2) and carbon monoxide (CO) concentrations in the flue gas and flue gas temperature. Compare results with values given on factory firetest report supplied with the water heater.

DANGER

Failure to properly adjust excess air will result in unsafe levels of carbon monoxide. Variations in venting or combustion air pressure and temperature will change excess air. Adjust excess air levels so that variation in venting or combustion air pressures and temperatures caused by change of seasons, wind conditions, opening or closing of mechanical room doors or windows do not cause the water heater to operate with carbon monoxide concentrations above or over 400 parts per million.

EE. Verify that all safety and operating limits and flame controls are operating properly. These controls and limits include combustion air switch, water temperature operating control, manual reset water temperature safety limit, vestibule fuseable link, mixer fuseable link, high and low gas pressure switches. Refer to manuals for these components for proper start-up and operating instructions. Follow all instructions contained in these manuals. This manual was provided with the water heater.

FF. Set Operating Limits - The thermostat is adjusted to its lowest temperature position when shipped from the factory. To set the operating water heater water temperature for on/off and 2-Stage appliance, rotate the dial of the "operating" aquastat to the appropriate temperature setting. The intent on the thermostat is the preferred starting point for setting the temperature control.

To set the operating water temperature for modulating water heaters refer to Appendix A - Digital Temperature Controller for Modulating Water Heaters.

GG. Replace access panels and turn water heater off. Allow system and appliance water to cool.

HH. After water heater and system water has cooled to less than 80°F, turn water heater on and observe the return water temperature from the system. If the return water temperature rises to above 120°F in less than five (5) minutes, leave the bypass balancing valve fully closed. If return water temperature is not above 120°F or it takes a longer period than five (5) minutes to rise above 120°F, slowly open bypass balancing valve. Continue to open bypass balancing valve so that return water temperature to the water heater is above 140°F. Note that if the temperature does not rise above 140°F with the bypass valve fully open, slowly begin to close balancing valve in the system and return piping until appliance return water temperature is above 140°F. Turn water heater off and allow water heater and system water to cool to less than 80°F. Turn water heater on and note return water temperature to the water heater. Confirm that water temperature rises above 120°F in less than five (5) minutes. If not, continue to open bypass balancing valve.

Modulating water heaters utilize a PID digital temperature control, where the set point cannot be set lower than 140°F, using a 5°F lower differential setting, for 20°F ΔT.

II. When water adjustment is complete, allow water heater to operate and confirm proper operation. Place system control back in normal operation.

WARNING

There is a hot water scald potential if the thermostat is set too high.

Should overheating occur or the gas supply fail to shut off, turn off the manual gas control valve to the appliance.

Do not operate water heater without air filter in place and securely fastened and sealed. Replacement air filters must be purchased from authorized Thermal Solutions representatives.

Do not readjust gas regulator, bypass water valve, system return water valve, system supply water valve, pressure switch or water flow switch from setting determined during system start-up. Do not tamper with any other water heater components.

AVERTISSEMENT

En cas de surchauffe ou si l'alimentation en gaz ne s'arrête pas, fermez manuellement le robinet d'arrêt de l'admission

V. Operation

FOR YOUR SAFETY, READ BEFORE OPERATING



WARNING: If you do not follow these instructions exactly, a fire or explosion may result causing property damage, personal injury, or loss of life.

- A. This appliance is equipped with an ignition device which automatically lights the pilot. Do NOT try to light the pilot by hand.
- B. BEFORE OPERATING smell all around the appliance area for gas. Be sure to smell next to the floor because some gas is heavier than air and will settle on the floor.
- If you cannot reach your gas supplier, call the fire department.
- C. Do not use this appliance if any part has been under water. Immediately call a qualified service technician to inspect the appliance and to replace any part of the control system and any gas control which has been under water.

WHAT TO DO IF YOU SMELL GAS

- Do not try to light any appliance.
- Do not touch any electric switch; do not use any phone in your building.
- Immediately call your gas supplier from a neighbor's phone. Follow the gas supplier's instructions.

OPERATING INSTRUCTIONS

1. STOP! Read all the safety information (warnings, cautions etc.) in this manual.
2. Turn off all electric power to the appliance.
3. Set the system control so that there is no call for heat to the water heater.
4. This water heater is equipped with an ignition device which automatically lights the pilot and main burner. Do not try to light the pilot or main flame by hand.
5. Remove front door panel.
6. Locate the gas pilot valve at the rear of the water heater.
7. Locate the gas main valves at the rear of the water heater and at the end of the gas supply pipe inside the water heater.
8. Rotate gas shutoff valves clockwise  from "ON" position to "OFF". Make sure handle rests against stop.
9. Wait five (5) minutes to clear out any gas. Then smell for gas, including near the floor. If you smell gas, STOP! Follow "B" in the safety information above on this label. If you do not smell gas, go to the next step.
10. Rotate gas shutoff valves counterclockwise  from "OFF" to "ON". Make sure handle rests against stop. Do not force.
12. Turn on all electric power to the appliance.
13. Set thermostat to desired setting.
14. If the appliance will not operate, follow the instructions " TO TURN OFF GAS TO APPLIANCE" and call your service technician or gas supplier.
15. Move the switch to the "ON" position.
16. Set system control so that there is a call for heat from the system.
17. Observe prepurge, pilot ignition and main flame ignition.
18. If pilot or main flame ignition does not occur during initial attempt, remove the upper front jacket panel of the water heater. If the water heater pilot and main flame light, go to step 20.

OPERATING INSTRUCTIONS CONTINUED

19. Reset the burner control by pressing the reset button located on the burner control. If you do not know where the control reset button is, do not touch any part of the control system or wiring. Turn all gas and electrical power off to the appliance and call a qualified service technician.

120. Replace the upper front jacket panel.

21. Observe several on and off cycles of the water heater. If any light offs are excessively noisy or rough, or any questionable boiler operation is noticed, immediately turn off all gas and electrical power and call qualified service technician.

22. Should overheating occur or the gas supply fail to shut off, turn off the manual gas control to the appliance.

Turn off Gas to the Appliance

1. Set the thermostat to lowest setting.

2. Turn off electric power to the appliance if service is to be performed.

3. Remove front door.

4. Rotate gas main shutoff valves, located inside the appliance, clockwise  from "ON" position to "OFF". Make sure handle rests against stop.

5. Replace front door.

6. At the rear of the unit, rotate the pilot and main gas valves clockwise  from "ON" position to "OFF". Make sure handle rests against stop.

POUR VOTRE SÉCURITÉ LISEZ AVANT DE METTRE EN MARCHÉ

AVERTISSEMENT: Quiconque ne respecte pas à la lettre les instructions dans la présente notice risque de déclencher un incendie ou une explosion entraînant des dommages, des blessures ou la mort.

- A. Cet appareil est muni d'un dispositif d'allumage qui allume automatiquement la veilleuse. Ne tentez pas d'allumer la veilleuse manuellement.
- B. AVANT DE FAIRE FONCTIONNER, reniflez tout autour de l'appareil pour détecter une odeur de gaz. Reniflez près du plancher, car certains gaz sont plus lourds que l'air et peuvent s'accumuler au niveau du sol.
- C. N'utilisez pas cet appareil s'il a été plongé dans l'eau, même partiellement. Faites inspecter l'appareil par un technicien qualifié et remplacez toute partie du système de contrôle et toute commande qui ont été plongés dans l'eau.
- QUE FAIRE SI VOUS SENTEZ UNE ODEUR DE GAZ:
- Ne pas tenter d'allumer d'appareil.
 - Ne touchez à aucun interrupteur ; ne pas vous servir des téléphones se trouvant dans le bâtiment..
 - Appelez immédiatement votre fournisseur de gaz depuis un voisin. Suivez les instructions du fournisseur.
 - Si vous ne pouvez rejoindre le fournisseur, appelez le service des incendies.



INSTRUCTIONS DE MISE EN MARCHÉ

1. ARRÊTEZ ! Lisez les instructions de sécurité sur la portion supérieure (à gauche) de cette étiquette.
2. Coupez l'alimentation électrique de l'appareil.
3. Réglez le thermostat à la température la plus basse.
4. This water heater is equipped with an ignition device which automatically lights the pilot and main burner. Do not try to light the pilot or main flame by hand.
5. This appliance is equipped with an ignition device, which automatically lights the pilot. Do not try to light the pilot by hand.
6. Remove front door panel.
7. Locate the gas pilot valve at the rear of the water heater.
8. Locate the gas main valves at the rear of the water heater and at the end of the gas supply pipe inside the water heater.
9. Rotate gas shutoff valves clockwise  from "ON" position to "OFF". Make sure handle rests against stop.
10. Attendre cinq (5) minutes** pour laisser échapper tout le gaz. Reniflez tout autour de l'appareil, y compris près du plancher, pour détecter une odeur de gaz. Si vous sentez une odeur de gaz, ARRÊTEZ ! Passez à l'étape B des instructions de sécurité sur la portion supérieure (à gauche) de cette étiquette. S'il n'y a pas d'odeur de gaz, passez à l'étape suivante.
11. Rotate gas shutoff valves counterclockwise from "OFF" to "ON". Make sure handle rests against stop. Do not force.
12. Mettez l'appareil sous tension.
13. Réglez le thermostat à la température désirée.
14. If the appliance will not operate, follow the instructions " TO TURN OFF GAS TO APPLIANCE" and call your service technician or gas supplier.
15. Move the switch to the "ON" position.
16. Set system control so that there is a call for heat from the system.
17. Observe prepurge, pilot ignition and main flame ignition.
18. If pilot or main flame ignition does not occur during initial attempt, remove the upper front jacket panel of the water heater. If the water heater pilot and main flame light, go to step 19.
19. Reset the burner control by pressing the reset button located on the burner control. If you do not know where the control reset button is, do not touch any part of the control system or wiring. Turn all gas and electrical power off to the water heater and call a qualified service technician.
20. Replace the upper front jacket panel.

INSTRUCTIONS DE MISE EN MARCHÉ

21. Observe several on and off cycles of the water heater. If any light offs are excessively noisy or rough, or any questionable boiler operation is noticed, immediately turn off all gas and electrical power and call qualified service technician.
22. Should overheating occur or the gas supply fail to shut off, turn off the manual gas control to the appliance.

Comment couper l'admission de gaz de l'appareil

1. Réglez le thermostat à la tempé la température la plus basse.
2. Coupez l'alimentation électrique de l'appareil s'il faut procéder à l'entretien.
3. Remove front door.
4. Rotate gas main shutoff valves, located inside the appliance clockwise  from "ON" position to "OFF". Make sure handle rests against stop.
5. Replace front door.
6. At the rear of the unit, rotate the pilot and main gas valves clockwise  from "ON" position to "OFF". Make sure handle rests against stop.

VI. Service/Maintenance

A. General Guidelines

1. A thorough and complete water heater inspection and check must be conducted a minimum of one (1) time per year.
2. Follow any checks and/or inspections that may be required as specified in the component manufacturer's instruction manuals.
3. Repair or replace any defective components immediately.
4. The following service procedures are required for proper and safe water heater operation.

CAUTION

Label all wires prior to disconnection when servicing controls. Wiring Errors can cause improper and dangerous operation.

Verify proper operation after servicing.

USE caution when servicing components behind upper front jacket panel. Filter/mounting bracket may cause head injury.

ATTENTION

Au moment de l'entretien des commandes, étiquetez tous les fils avant de les débrancher. Des erreurs de câblage peuvent entraîner un fonctionnement inadéquat et dangereux.

WARNING

This water heater must only be serviced and repaired by skilled and experienced service technicians.

If any controls are replaced, they must be replaced with identical models.

Read, understand and follow all the instructions and warnings contained in all the sections of this manual.

If any electrical wires are disconnected during service, clearly label the wires and assure that the wires are reconnected properly.

Never jump out or bypass any safety or operating control or component of this appliance.

Read, understand and follow all the instructions and warnings contained in ALL of the component instruction manuals.

Assure that all safety and operating controls and components are operating properly before placing the water heater back in service.

The service instructions contained in this manual are in addition to the instructions provided by the manufacturer of the water heater components. Follow component manufacturer's instructions. Component manufacturer's instructions were provided with the water heater. Contact component manufacturer for replacement if instructions are missing. Do not install, start up, operate, maintain or service this appliance with out reading and understanding all of the component instructions. Do not allow the appliance to operate with altered, disconnected or jumpered components. Only use replacement components identical to those originally supplied by Thermal Solutions.

DANGER

This water heater uses flammable gas, high voltage electricity, moving parts, and very hot water under high pressure. Assure that all gas and electric power supplies are off and that the water temperature is cool before attempting any disassembly or service. More than one gas shut-off valve and electrical disconnect switch are used on the water heater. Assure that all gas valves and electrical disconnect switches are off before attempting any disassembly or service.

Do not attempt any service work if gas is present in the air in the vicinity of the water heater. Never modify, remove or tamper with any control device.

B. Daily Water Heater Inspection & Check

1. Inspect the area to assure proper clearance from combustible materials, gasoline, and other flammable vapors, and liquids.
2. Observe burner color. See Item H.
3. Check flame control for proper operation and shutdown.
4. Check vent and air intake piping for any obstructions.
5. Check for any water leaks.
6. Check for any gas leaks.
7. Check condensate drains for any obstructions.
8. Clean any debris or trash from area.
9. Check the low draft, fan, air pressure, and damper position interlocks, according to the manufacturer's instructions, if so equipped.
10. Check gauges, monitors, and indicators to assure they are functioning properly.
11. Log that the above maintenance was completed in a appliance log. Maintain log near appliance location.

C. Weekly Water Heater Inspection & Check

1. Check flame strength for both pilot and main flames; log.
2. Check igniter.
3. Check operation of the flame failure detection system for both pilot and main flame.
4. Check firing rate control for proper operations.
5. Check pilot and main fuel valves
 - a) open limit switch and make aural and visual inspection; check valve position indicators and fuel meters, if provided.
6. Check the low water cutoff device & alarm according to the manufacturer's instructions.

D. Monthly Safety and Operating Control Checks

1. Check proper operation of all safety and operating controls including flame safeguard.
2. Check proper operation of safety relief valve.
3. Check condition of water (pH, alkalinity, hardness). Correct water condition as needed.
4. Check carbon monoxide level in flue products.
5. Check venting/air intake and condensate drain tubes for obstructions.

6. Repair or replace any inoperative or damaged components.
7. Low water cutoff, float type (If so equipped)
 - a) Monthly Blow-off. During the heating season, if an external float type low water cutoff is above the water heater, the blow off valve should be opened once a month (use greater frequency where conditions warrant), to flush out the sediment chamber so the device will be free to function properly.
8. Inspect and replace air filter as needed.
9. Check high and low gas pressure switch interlocks.
10. Log service procedure in appliance log.

E. Semi-Annual "Tune-up"

1. Inspect condensate drain tubes for deterioration, cracking, etc.
2. Inspect air intake and exhaust pipes for leaks, deterioration, scale, etc.
3. Measure fuel input, oxygen and carbon monoxide in flue products.
4. Adjust burner to obtain values noted in firetest report.
5. Complete safety and operating control checks.
6. Repair or replace any inoperative or damaged components.
7. Log service procedures in water heater log.

F. Annual Inspection and Check.

1. Replace air filter (recommended).
2. Remove and inspect pilot assembly.
3. Remove lower front jacket panel and check for any signs of corrosion and leaks.
4. Remove pipe plugs in header and inspect inside of copper tubes and header.
5. Flush water heater and mechanically remove any scale.
6. Remove, inspect and clean water flow switch and low water cut-off(s).
7. Complete "tune up" procedures. (See Item D.)
8. Log service procedures in appliance log.
9. Repair or replace any inoperative or damaged components.

10. Vent/Air Intake System. Inspect for obstructions, soot accumulation, proper support, and deterioration of pipe, fittings, and joints.

- a) Clean terminal screens. Terminals must be free of obstruction, undamaged, with screens securely in place.
- b) Terminal and wall thimbles (if used) must be weather-tight.
- c) Pipe must be full round shape, and show no damage from impact or excessive temperature.
- d) Pipe must be supported at minimum five (5) foot intervals and must not sag.
- e) All vent joints must be secure and watertight.
- f) Horizontal vent tee drain or vertical vent tee drain (if used) must have minimum 6 inch trap and allow condensate to flow freely. To clean:
 - i) Disconnect drain tube from drain fitting.
 - ii) Flush drain tube with water. Fill trap with water.
 - iii) Securely fasten drain tube to drain fitting, providing gas-tight and watertight seal.
- g) If pipe must be disassembled for removal of obstructions or resealing of joint, see venting section of the manual.

11. Low Water Cutoff (if so equipped)

- a) Float type low water cutoffs should be dismantled annually by qualified personnel, to the extent necessary to insure freedom from obstructions and proper functioning of the working parts.
 - i) Inspect connecting lines to water heater for accumulation of mud, scale, etc., and clean as required.
 - ii) Examine all visible wiring for brittle or worn insulation and make sure electrical contacts are clean and that they function properly. Give special attention to solder joints on bellows and float when this type of control is used.
 - iii) Check float for evidence of collapse and check mercury bulb (where applicable) for mercury separation or discoloration.

- b) Probe Type (Annual Service). Probe type LWCO should be removed once a year, examined and cleaned of any dirt accumulations to assure proper operations. Do not attempt to repair mechanisms in the field. Complete replacement mechanisms including necessary gaskets and installation instructions, are available from the manufacturer.

12) Verify Proper Operation after servicing.

G. Air Filter:

- A. Perform a visual inspection of air filter and replace as necessary
 1. Remove upper front panel
 2. Remove red tube from nipple on filter assembly
 3. Remove wing nut
 4. Remove filter assembly from appliance
 5. Remove foam pre-filter and wash with soap and water.
 6. Replace primary filter as necessary

H. Pilot and Main Flame:

- A. Perform a visual inspection of pilot burner flame.
 1. Refer to the flame safeguard instruction manual and conduct a pilot turndown test.
 2. Observe pilot operation and record pilot signal. Flame should be steady medium hard blue clearly visible through sight glass.
- B. Pilot Cleaning and Maintenance
 1. Shut off gas supply and disconnect electrical service.
 2. Disconnect scanner, ignition electrode, loosen and remove pilot gas line and combustion air line from fan.
 3. Remove mounting fasteners and pull pilot assembly from heat exchanger.
 4. Examine pilot electrode and set gap to 1/8" if needed. Clean as required.
 5. Reassemble in reverse order using a new gasket available from Thermal Solutions.
- C. Perform a visual inspection of main burner flame.
 1. Observe main flame and record flame signal. Flame should be steady deep orange in color with dark blue checkerboard pattern throughout.
 2. Main burner requires no cleaning or annual maintenance

I. Check Combustion and Safety Controls:

- A. Check flame failure detection system with system operating.
 - 1. Pilot
 - a. Refer to the flame safeguard instruction manual.
 - b. Manually close pilot fuel supply and verify lock out of primary control.
 - 2. Main Flame
 - a. Refer to the flame safeguard instruction.
 - b. Close manual main fuel shut off valve and verify lockout of primary control.

J. Burner:

- A. Inspect visually. No maintenance is required.

CAUTION

Do not attempt to remove or service burner. Damage to the burner may result. Consult manufacturer.

K. Safety and Operating Controls, Operation and Shutdown

Component	Function
Control Circuit Breaker	If the power draw of the control circuit exceeds approximately 5 amps, the circuit breaker trips and prevents the appliance from powering until circuit breaker is reset.
Power Switch	If this switch is in the off position, power is interrupted to the control circuit of the appliance which prevents the appliance from operating. If the switch is in the on position, power is supplied to the control circuit.
Operating Aquastat	If the water temperature exceeds the adjustable set point, power is interrupted to the control circuit of the appliance which prevents the appliance from operating. When the water temperature drops below the set point minus the adjustable differential setting, power is again supplied to the control circuit.
Manual Reset High Limit Aquastat	If the water temperature exceeds the adjustable set point, power is interrupted to the control circuit of the appliance which prevents the appliance from operating. Power is interrupted until the control is manually reset by pressing the control's reset button. When the button is depressed, power will again be supplied to the control circuit.
Flow Switch	If the water flow through the appliance drops below the fixed flow rate required to move the control's paddle enough to close the controls contacts, power is interrupted to the control circuit, which prevents the appliance from operating. When the water flow rate is increased, the paddle closes the control's contacts and power is supplied to the control circuit.
Pressure (Safety) Relief Valve	If the pressure inside the appliance exceeds the fixed set point, the valve opens mechanically and discharges water. The valve remains open until the pressure inside the appliance drops below the set point.
Mixer Fuseable Link	If the temperature in the interior of the burner exceeds the fixed set point, the contacts of the switch open and power is interrupted to the control circuit which prevents the appliance from operating. Power is interrupted until the switch is replaced.
Vestibule Fuseable Link	If the temperature in the interior of the vestibule enclosure exceeds the fixed set point, the contacts of the switch open and power is interrupted to the control circuit which prevents the appliance from operating. Power is interrupted until the switch is replaced.
High and Low Gas Pressure Switches	If the gas pressure reaches a point below the adjustable set point, or above the adjustable set point, the contacts of the switch open and power is interrupted to the control circuit which prevents the appliance from operating. Power is interrupted until gas pressure is between the high and low set points and the control is manually reset by moving the switch to the reset position. The switches will not reset until the gas pressure is within the set point parameters.
Combustion Air Flow Switch	If the differential air pressure drops below the fixed set point, the contacts of the switch open and power is interrupted to the control circuit, which prevents the appliance from operating. Power is interrupted until air flow increases so that the contacts close.
Flame Safeguard Control	Refer to the manual supplied with the appliance.
Variable Frequency Drive (VFD)	The variable frequency drive's primary function is to vary the rotational speed of the blower fan based on the air requirements of the combustion process. The VFD is used for Modulating models. The VFD responds to a 4-20 mA signal from the Digital Temperature Controller.
Digital Temperature Controller	The microprocessor based temperature controller is used on all modulating units. The controller's basic function is to control the firing rate of the appliance based on the difference between the bulk water temperature and the controller's set-point. The controller also has the ability to change the operating set-point based on an external signal (contact closure for reduced demand setting or outdoor reset.)

This Page is Deliberately Left Blank

L. Troubleshooting Guide

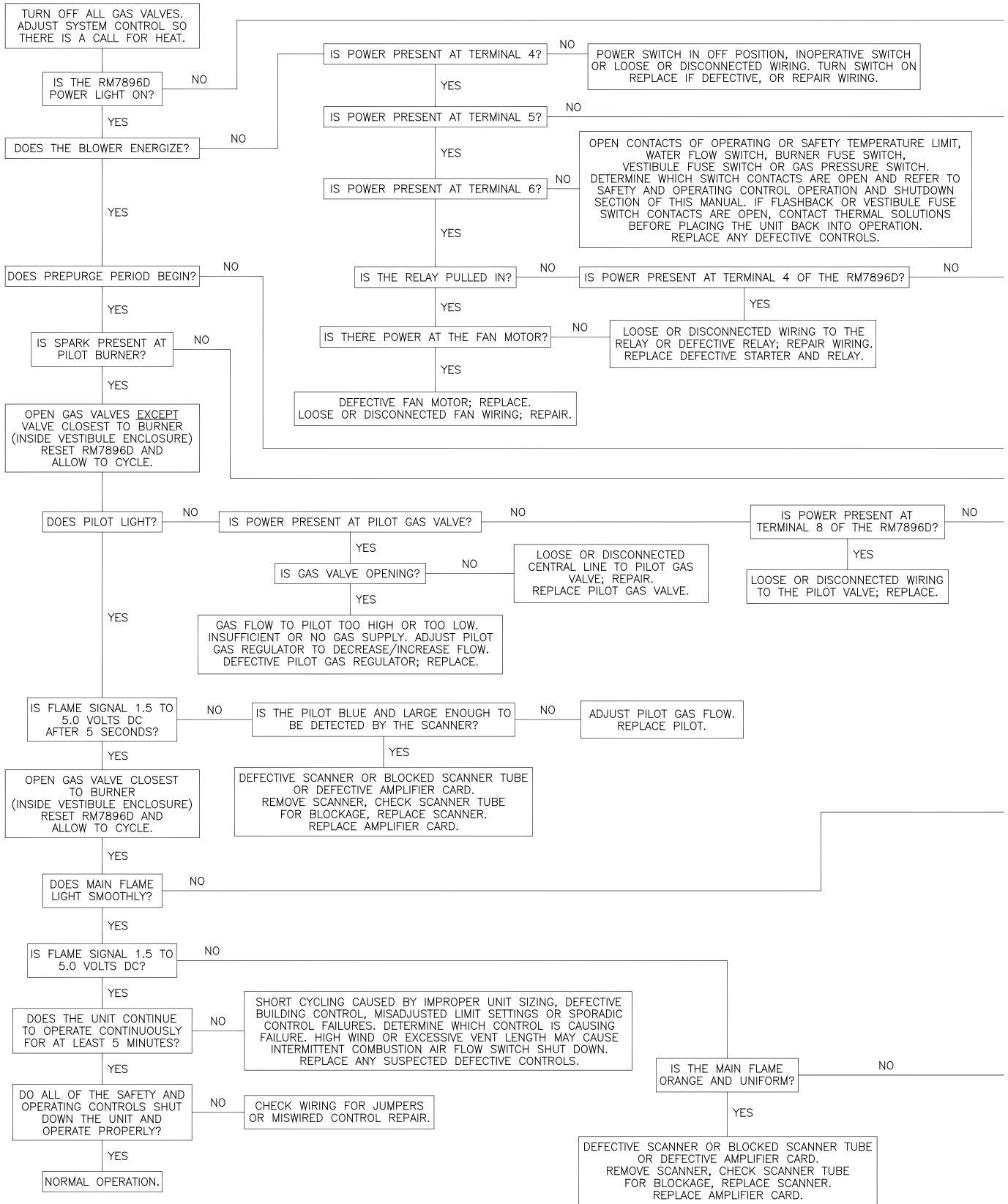

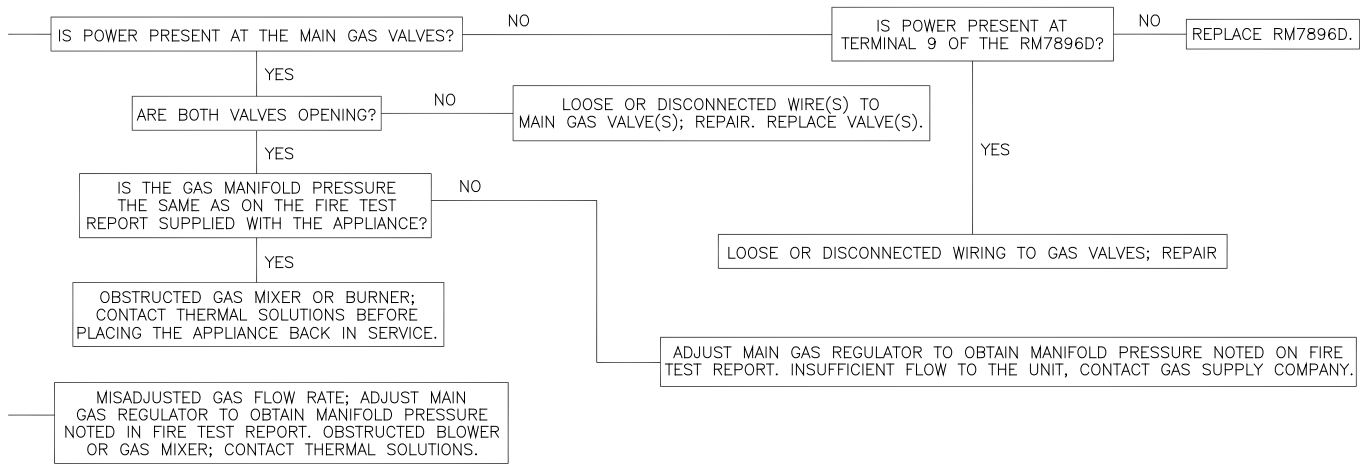
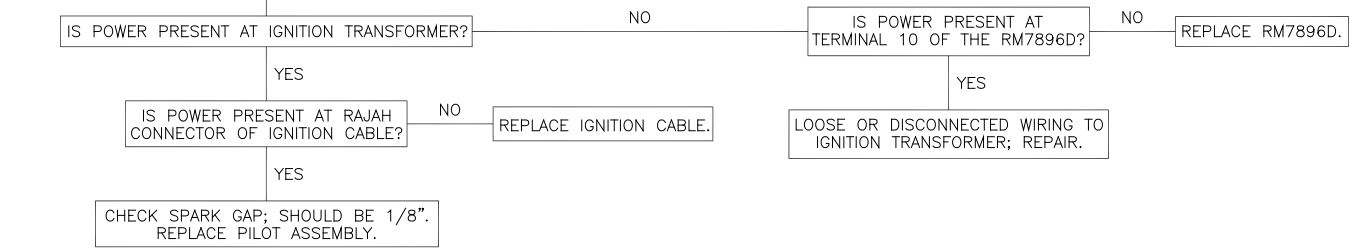
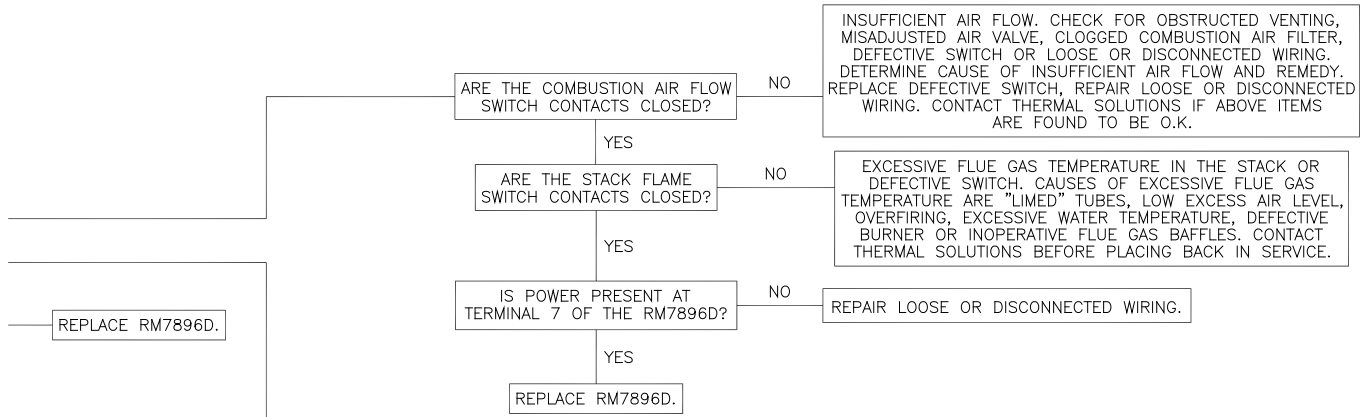
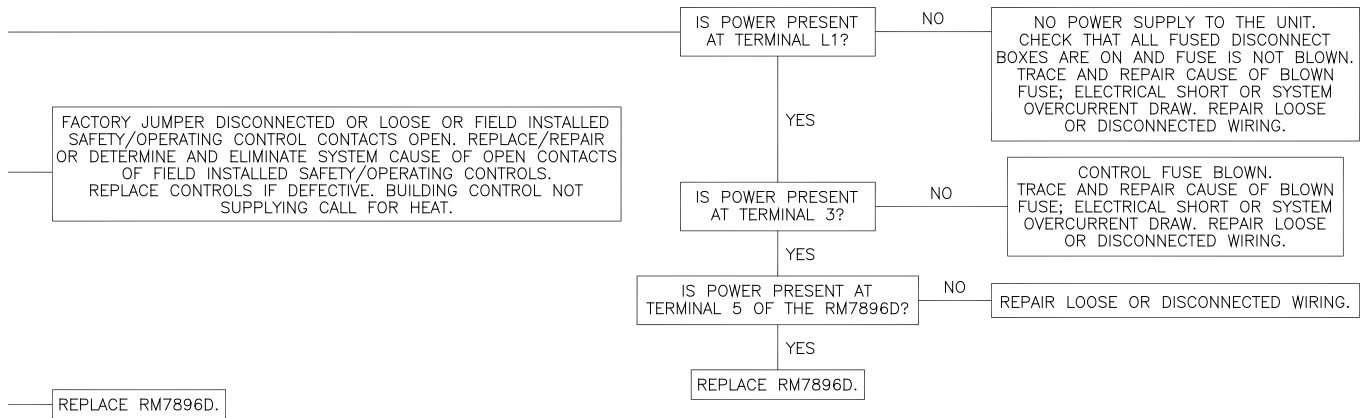

NOTICE

BEFORE REPLACING RM7896D, CONFIRM THAT ALL THE WIRING TO THE SUB-BASE IS SECURE AND THAT THE SUB-BASE CONTROLS ARE NOT BENT TO THE REAR.

M. NORMAL SEQUENCE OF OPERATION

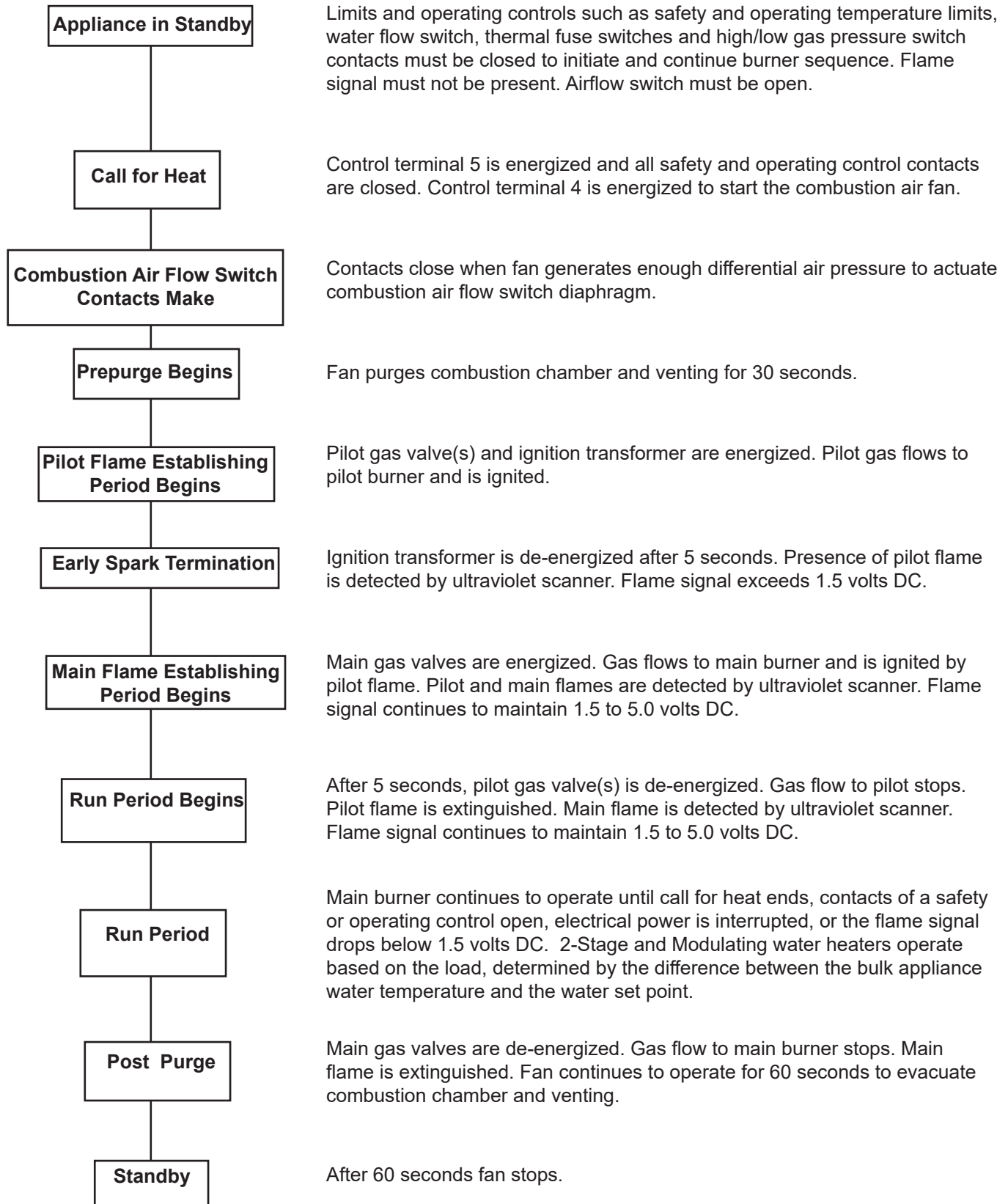

VII. Repair Parts

EVOW Series repair parts can be ordered through your nearest Thermal Solutions Representative for delivery from Lancaster, PA.

The Representatives can also advise as to the availability of product and repair parts from local sources.

Contact Thermal Solutions for your Representative at:

Thermal Solutions Products LLC
1175 Manheim Pike
Lancaster, Pennsylvania 17601
Telephone (717) 239-7642
Fax (877) 501-5212 (toll free)
www.thermalsolutions.com

WARNING

The repair parts noted in this section are for the standard EVOW Series water heater. Different contents and components may have been supplied due to the request of the equipment end user. Consult Thermal Solutions for repair parts on non-standard controls and components.

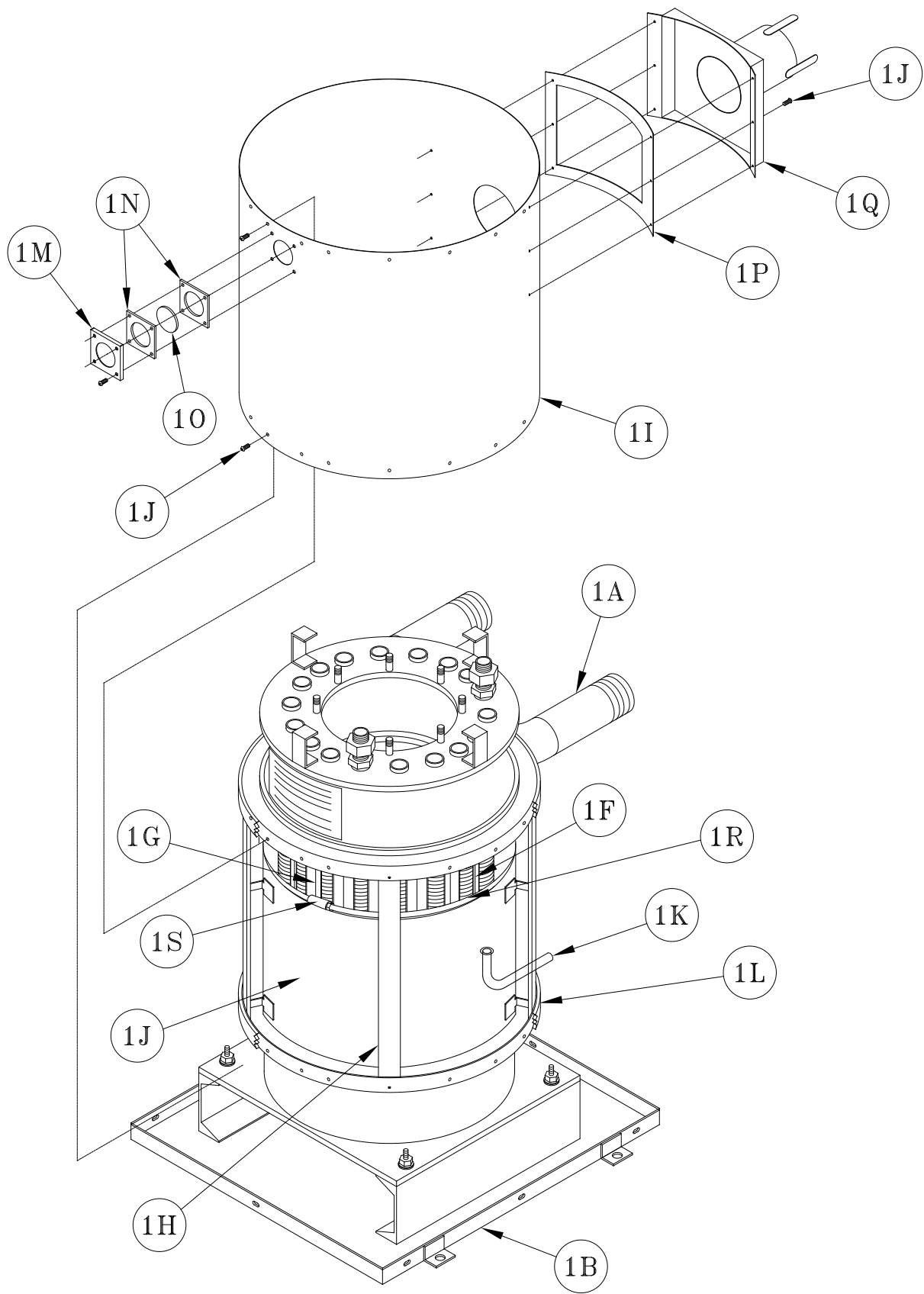

Figure 14: Combustion Chamber Assembly

WATER HEATER COMBUSTION CHAMBER					
Key No.	Description	Model Size			
		750	1000	1500	2000
1A	Heat Exchanger	(1) 603563009	(1) 603563010	(1) 603563011	(1) 603563012
1B	Base	(1) 61556025			
1F	Tube Baffle	(31) 70356215	(31) 70356216	(31) 70356217	(31) 70356218
1G	Sight Tube Baffle	(1) 70356223	(1) 70356224	(1) 70356225	(1) 70356226
1H	Combustion Pan support	(4) 603562041	(4) 603562051	(4) 603562061	(4) 603562071
1I	Heat Exchanger Wrapper	(1) 70356219	(1) 70356220	(1) 70356221	(1) 70356222
1J	Heat Exchanger Baffle	(1) 70356236	(1) 70356237	(1) 70356238	(1) 70356239
1K	Condensate Drain Tube	(1) 8065601			
1L	1" Fiber Gasket	(14LF) 9206032			
1M	Sight Glass Lens Retainer	(1) 7186019			
1N	Sight Glass Gaskets	(2) 8206039			
1O	Sight Glass Lens Retainer	(1) 8026082			
1P	Vent Connector Gasket	(1) 8205624			
1Q	Vent Connector	(1) 81156016	(1) 81156017		
1R	Wrapper Banding	(24 LF) 924660281			
1S	Banding Buckle	(4 LF) 808609461			

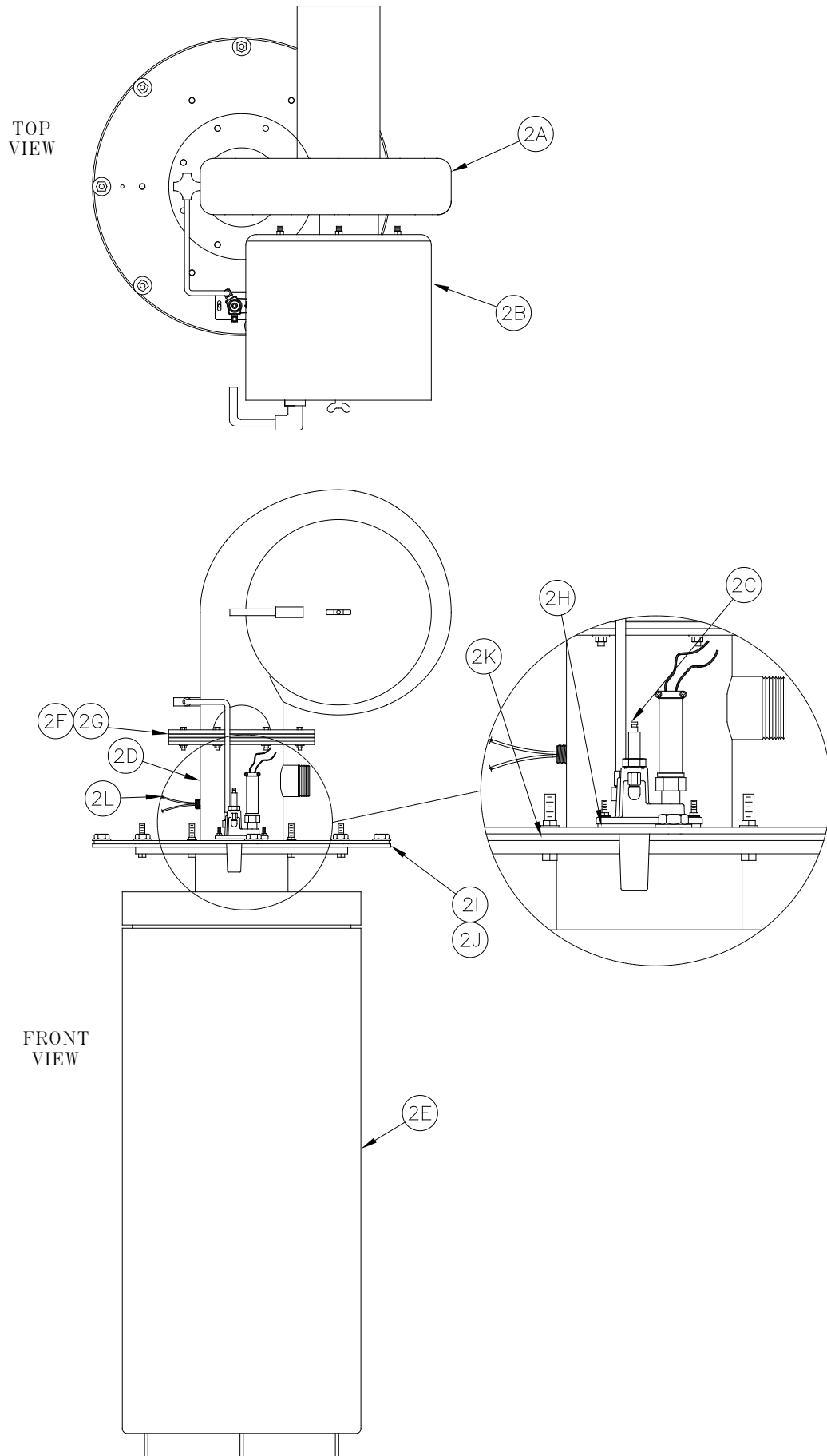

Figure 15: Burner Assembly

BURNER ASSEMBLY					
Key No.	Description	(Qty) Part Number			
		EVO-750	EVO-1000	EVO-1500	EVO-2000
2A	Fan (120/1 ph)	(1) 81156001			
	Fan (3 phase)	(1) 81156018			
2B	Air Filter	(1) 81156011			(1) 81156012
2C	Pilot Assembly - NG - OR - Pilot Assembly - LP	See Gas Train Drawings			
2D	Mixer Assembly - NG	(1) 60256209	(1) 60256210	(1) 60256211	(1) 60256212
	Mixer Assembly - LP	(1) 60256213	(1) 60256214	(1) 60256215	(1) 60256216
2E	Burner Element	(1) TS750CF	(1) TS1000CF	(1) TS1500CF	(1) TS2000CF
2F	Air Orifice Gasket	(2) 8205603			
2G	Air Orifice	(1) 80256235	(1) 80256253	(1) 80256236	(1) 80256237
2H	Pilot Gasket	(1) 8205608			
2I	Gas Mixing Orifice	N/A			
2J	Burner Gasket	(1) 82056041			
2K	Burner Mounting Flange Gasket	(1) 8205605			
2L	Burner Thermal Fuse Assembly	(1) 6025601			
2M	Vestibule Fuse Assembly (not shown)	(1) 6025602			

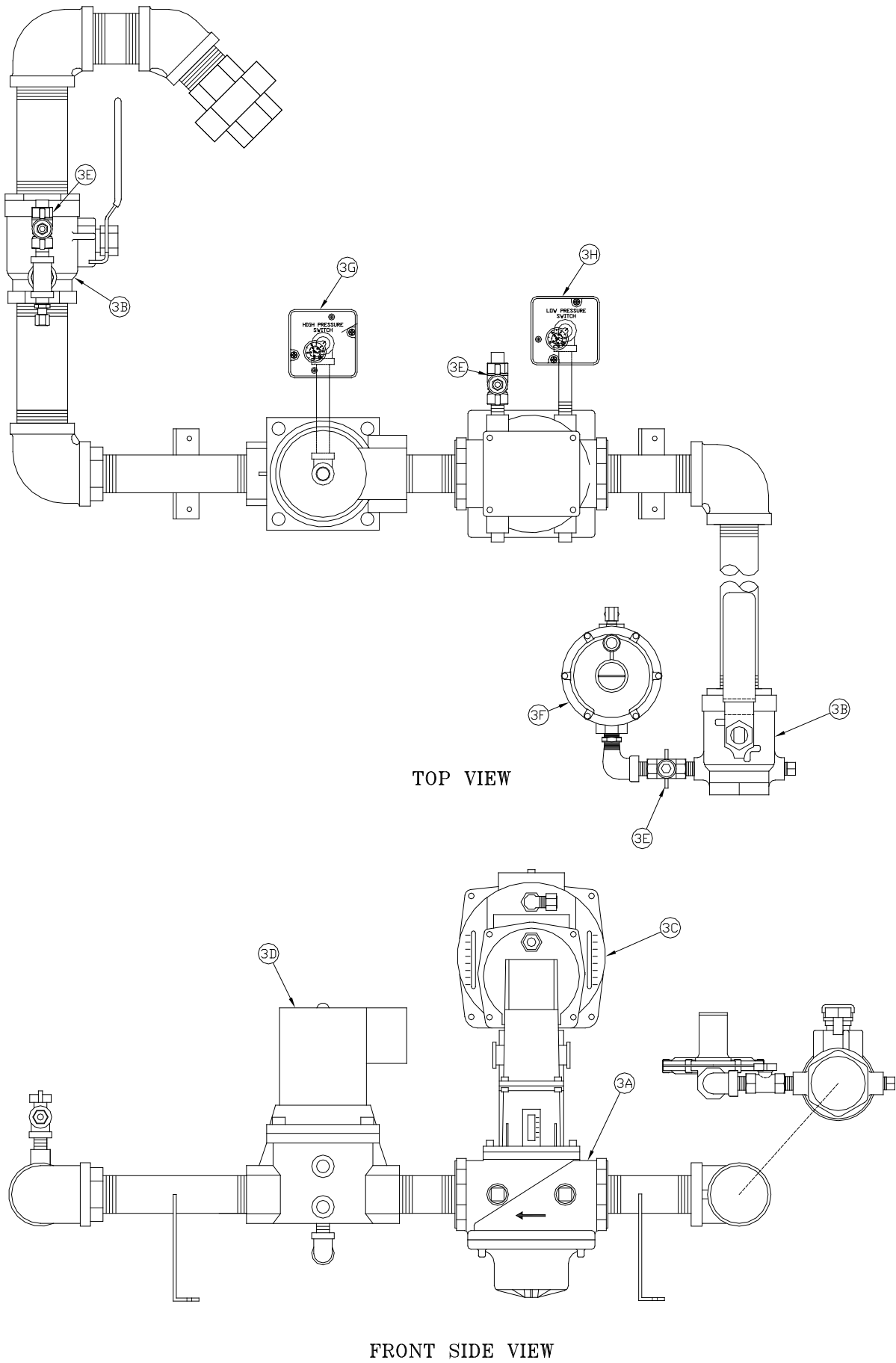
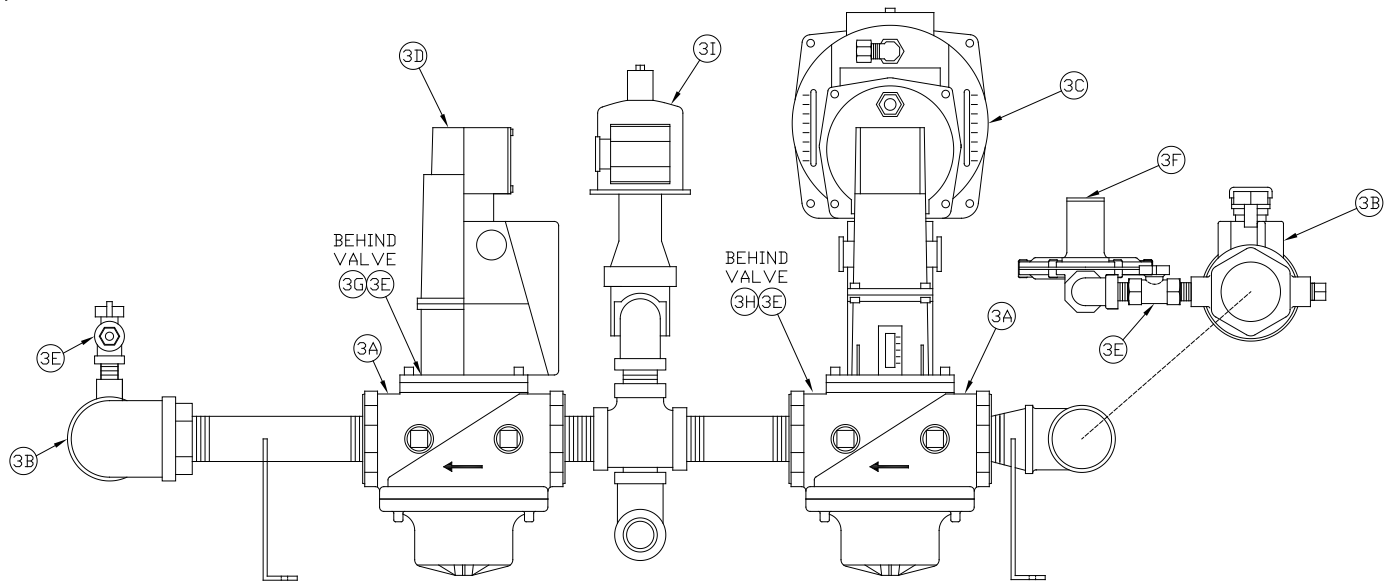

Figure 16: UL/FM/CSD-1 Main Gas Train Assembly

EVO Modulating, UL/FM/CSD-1			
Key No.	Description	(Quantity) Part Number	
		EVO-750	EVO-1000 to 2000
3A	Main Valve Body	(1) 816634041	(1) 81663404
3B	Manual Gas Valve	(2) 806603055	(2) 806603053
3C	Actuator	(1) 81663408	
3D	Solenoid Gas Valve	(1) 81660207	(1) 81660205
3E	Gas Cock	(3) 822758	
3F	Pilot Regulator	(1) 822702	
3G	High Pres. Switch	(1) 80160333	
3H	Low Pres. Switch	(1) 80160332	



FRONT SIDE VIEW

Figure 17: DB&B Gas Train (750)

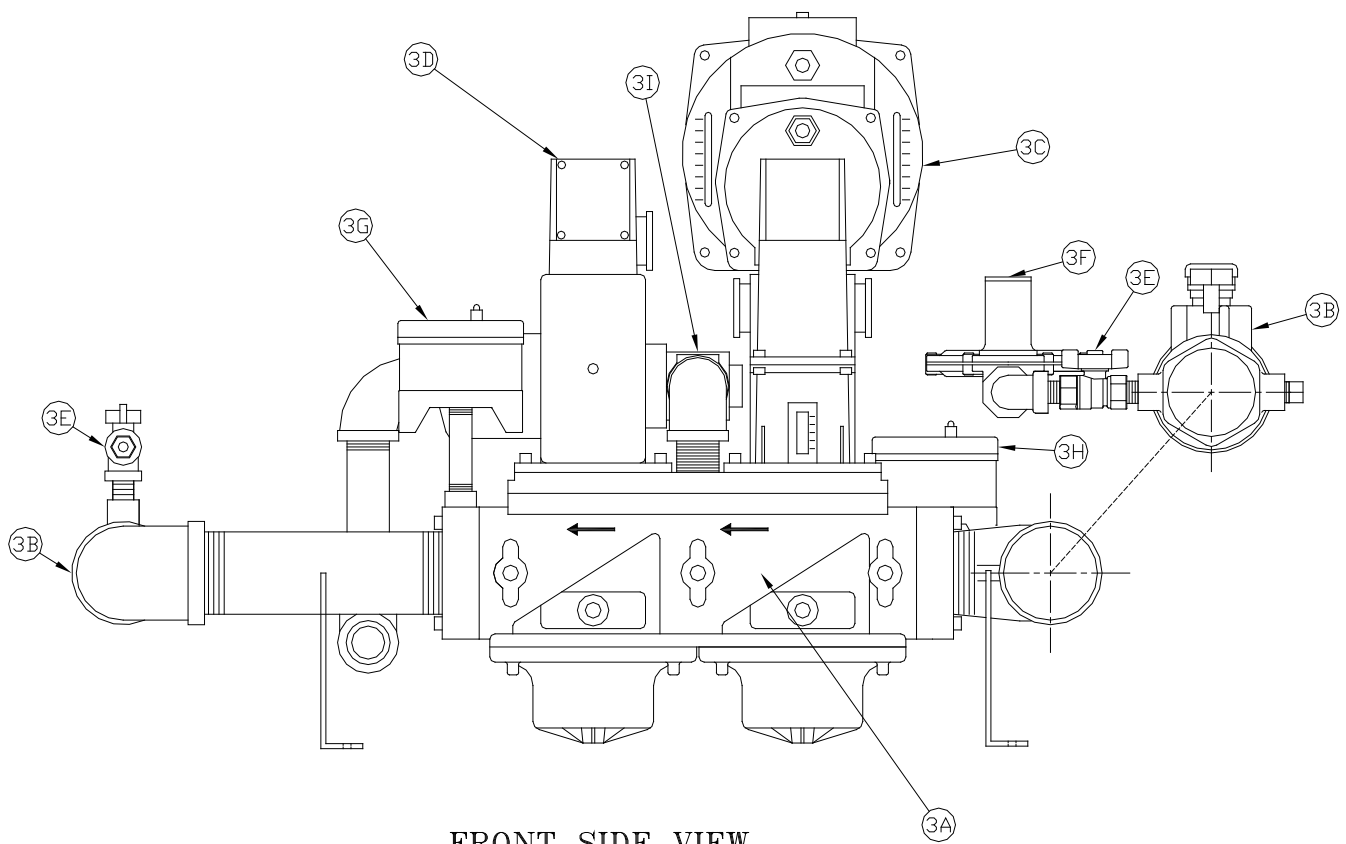

FRONT SIDE VIEW

Figure 18: DB&B Gas Train (1000-2000)

DB&B – MAIN AND PILOT					
Key No.	Description	(Quantity) Part Number			
		EVO-750	EVO-1000	EVO-1500	EVO-2000
MAIN AND PILOT GAS TRAIN					
3A	Main Gas Valve Body 1" NPT	(1) 816634041	—	—	—
	Main Gas Valve Body, DBL, 1-1/2" NPT	—	(1) 81663404		
3B	Manual Gas Valve with Pilot Tapping, 1" NPT	(1) 806603055	—	—	—
	Manual Gas Valve with Pilot Tapping, 1-1/2" NPT	(1) 806603053	(2) 806603053		
3C	DB&B Actuator/Regulator Ratio Valve, Siemens SKP75 (max 5 PSI)	(1) 81663408			
3D	DB&B Solenoid Valve	(1) 81660207	(1) 81660205		
3E	Manual Gas Cock, 1/4"	(3) 822758			
3F	Pilot Gas Regulator	(1) 822702			
3G	High Gas Pressure Switch	(1) 80160333			
3H	Low Gas Pressure Switch	(1) 80160332			
3I	Normally Open Vent Valve	(1) 81660748			

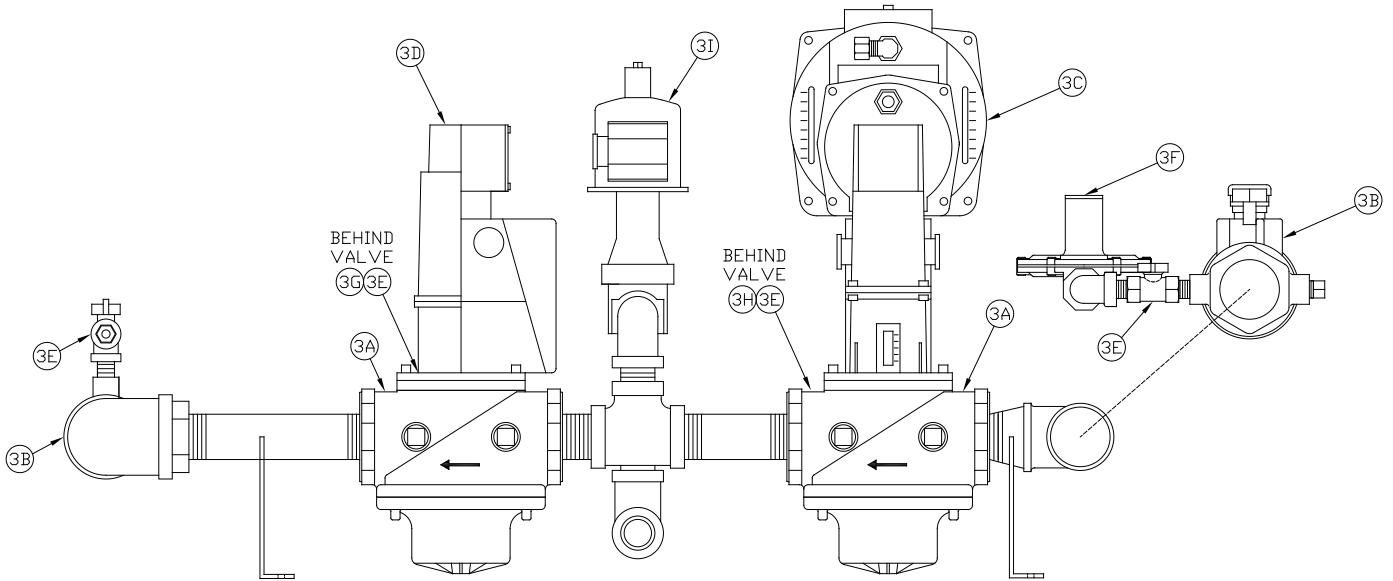

FRONT SIDE VIEW

Figure 19: DB&B w/POC Gas Train (750)

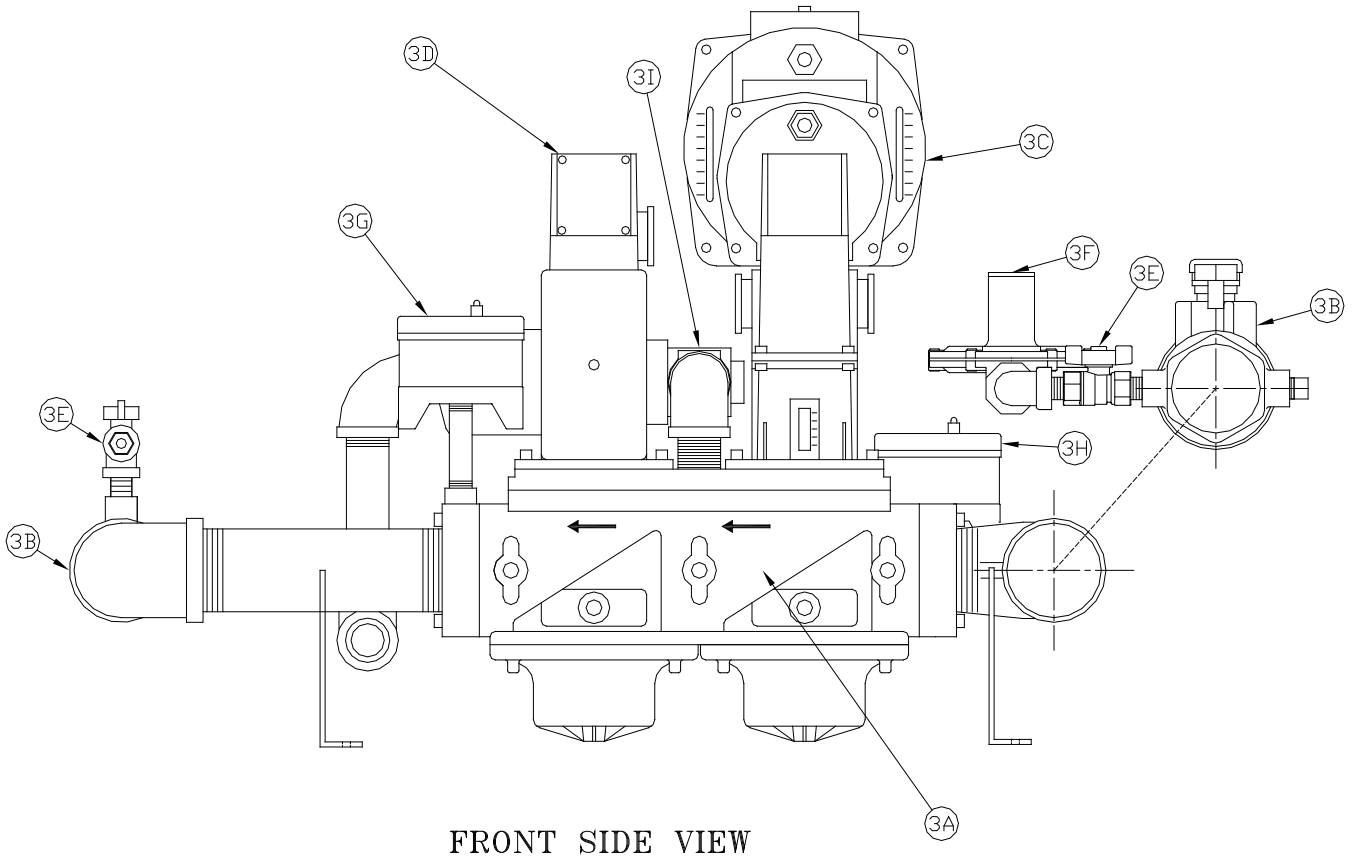

FRONT SIDE VIEW

Figure 20: DB&B w/POC Gas Train (1000-2000)

DB&B W/POC - MAIN AND PILOT		
Key No.	Description	(Quantity) Part Number
		EVO-750
Main and Pilot Gas Train		
3A	Main Gas Valve Body 1" NPT	(2) 816634041
3B	Manual Gas Valve with Pilot Tapping, 1" NPT	(2) 806603055
3C	Actuator/Regulator Ratio Valve, Siemens SKP75, (max 5psi), DB&B w/POC	(1) 81663409
3D	Actuator, Siemens SKP15, DB&B w/POC	(1) 81663407
3E	Manual Gas Cock, 1/4"	(3) 822758
3F	Pilot Gas Regulator	(1) 822702
3G	High Gas Pressure Switch	(1) 80160333
3H	Low Gas Pressure Switch	(1) 80160332
3I	Normally Open Vent Valve	(1) 81660262

DB&B W/POC – MAIN AND PILOT				
Key No.	Description			
		EVO-1000	EVO-1500	EVO-2000
MAIN AND PILOT GAS TRAIN				
3A	Main Gas Valve Body, DBL, 1-1/2" NPT		(1) 81663404	
3B	Manual Gas Valve with Pilot Tapping, 1-1/2" NPT		(2) 806603053	
3C	DB&B w/POC Actuator/Regulator Ratio Valve, Siemens SKP75 (max 5 PSI)		(1) 81663409	
3D	DB&B w/POC Actuator, Siemens SKP15		(1) 81663407	
3E	Manual Gas Cock, 1/4"		(3) 822758	
3F	Pilot Gas Regulator		(1) 822702	
3G	High Gas Pressure Switch		(1) 80160333	
3H	Low Gas Pressure Switch		(1) 80160332	
3I	Normally Open Vent Valve		(1) 81660748	

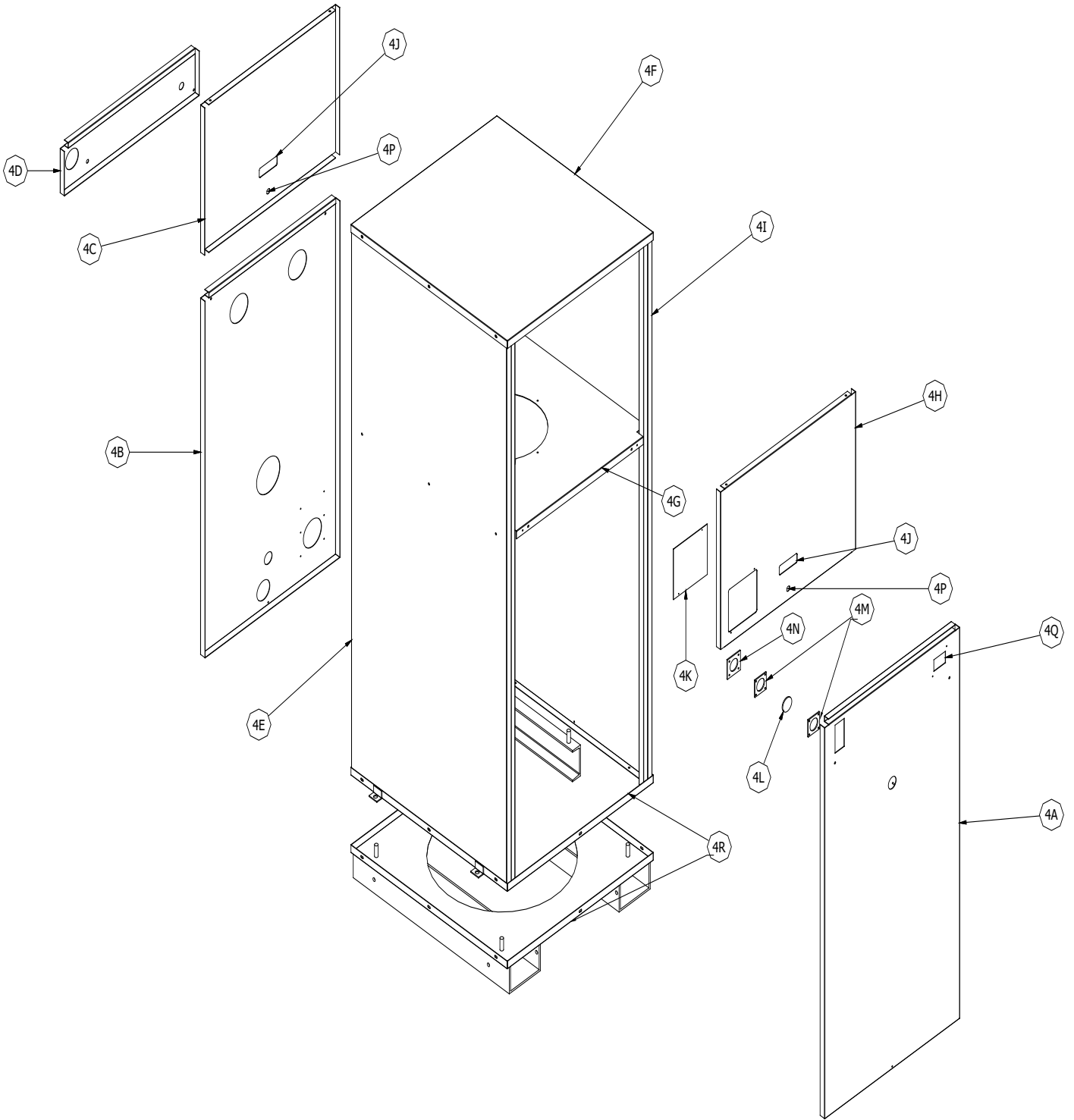

Figure 21: Jacket Panels

JACKET					
Key No.	Description				
		EVO-750	EVO-1000	EVO-1500	EVO-2000
Jacket Assembly					
	Jacket Lower Front Panel (Modulation)	(1) 60456311	(1) 60456312	(1) 60456313	(1) 60456314
4B	Jacket Lower Rear Panel	(1) 60456305	(1) 60456306	(1) 60456307	(1) 60456308
4C	Jacket Upper Rear Panel	(1) 70456251			
4D	Jacket Center Rear Panel	(1) 70456250			
4E	Jacket Panel Left Side	(1) 60456329	(1) 60456330	(1) 60456331	(1) 60456332
4F	Jacket Top Panel	(1) 70456254			
4G	Jacket Vestibule Panel	(1) 60456302			
4H	Jacket Upper Front Panel	(1) 70456252			
4I	Jacket Panel Right Side	(1) 60456323	(1) 60456324	(1) 60456325	(1) 60456326
4J	Handle	(2) 8056256			
4K	View Port Cover for Flame Safeguard	(1) 81356007			
4L	Observation Port Tens	(1) 8026082			
4M	Observation Port Gasket	(2) 8206039			
4N	Observation Port Lens Retainer	(1) 7186019			
4P	Latch	(2) 80861719			
4Q	Power Switch w/Filter Light	(1) 8136496			
4R	Base	(1) 6155604			
4S	Outdoor Vent Terminal (Not Shown)	(1) 102434-02	(1) 102434-04		

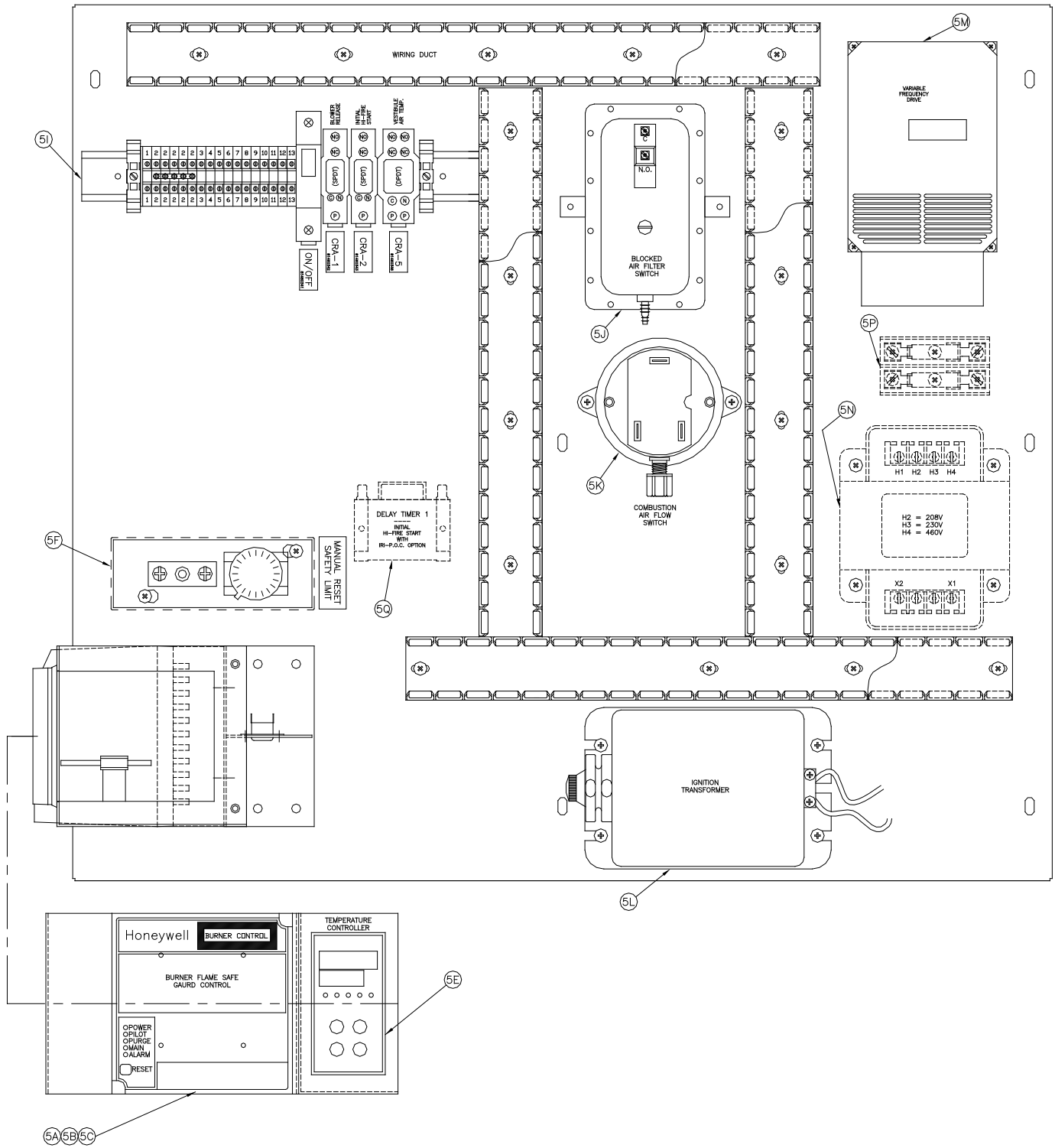

Figure 22: Control Panel Assembly (Modulation)

CONTROLS (Modulation)					
Key No.	Description				
		EVO-750	EVO-1000	EVO-1500	EVO-2000
Controls and Components					
5A	RM7896D1027 Flame Safeguard Control for UL/FM/CSD-1/DB&B	(1) 80160212			
	RM7840L1075 Flame Safeguard Control for DB&B w/POC & LFP	(1) 801602303			
	Modbus Module for 5A (optional - not shown)	(1) 80160909			
	Display Module for 5A (optional - not shown)	(1) 80160640			
5B	Amplifier Card (not shown) R7849A1023	(1) 80160243			
5C	Purge Card (not shown) ST7800A1039 (UL/FM, CSD-1)	(1) 8136362			
	Purge Card (not shown) ST7800A1005 (DB&B w/POC)	(1) 81363621			
5D	Power Switch with Filter Light (not shown)	(1) 8136363			
5E	Operating Limit, Digital Modbus, RWF55	(1) 106203-01			
5F	High Limit L4008E1305 (Manual Reset - max 240F)	(1) 80160667			
	High Limit L4008E1313 (Manual Rest - max 200F) (optional)	(1) 80160660			
5G	Water Flow Switch FS4-3 (not shown)	(1) 80160175			
5H	Vestibule Fuse Switch (not shown)	(1) 80160209			
5I	Terminal Block/Circuit Breaker Assembly	(1) 8136498			
5J	Blocked Filter Switch	(1) 80160295			
5K	Combustion Air Flow Switch	(1) 102382-02			
5L	Ignition Transformer	(1) 80160018			
5M	Variable Frequency Drive 115 volt input	(1) 80160933			
	Variable Frequency Drive 208/230 volt input	(1) 80160940			
	Variable Frequency Drive 460 volt input	(1) 80160941			
5N	Control Transformer (High Voltage Option)	(1) 80160820			
5P	Fuses and Fuse Block (High Voltage Option)	(2) 8136426 & (2) 8136427			
5Q	Delay Timer (No Timer for EVO 500-2000 UL/FM,CSD-1)	(1) 80160675			
5R	Resistor 1k 25watt (LFP option only) (not shown)	(1) 103577-01			

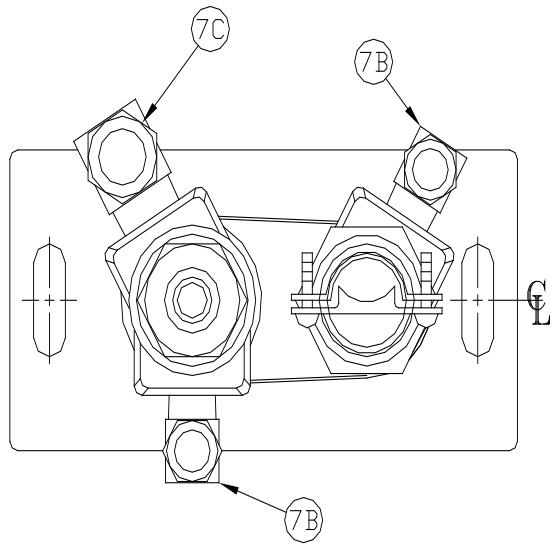
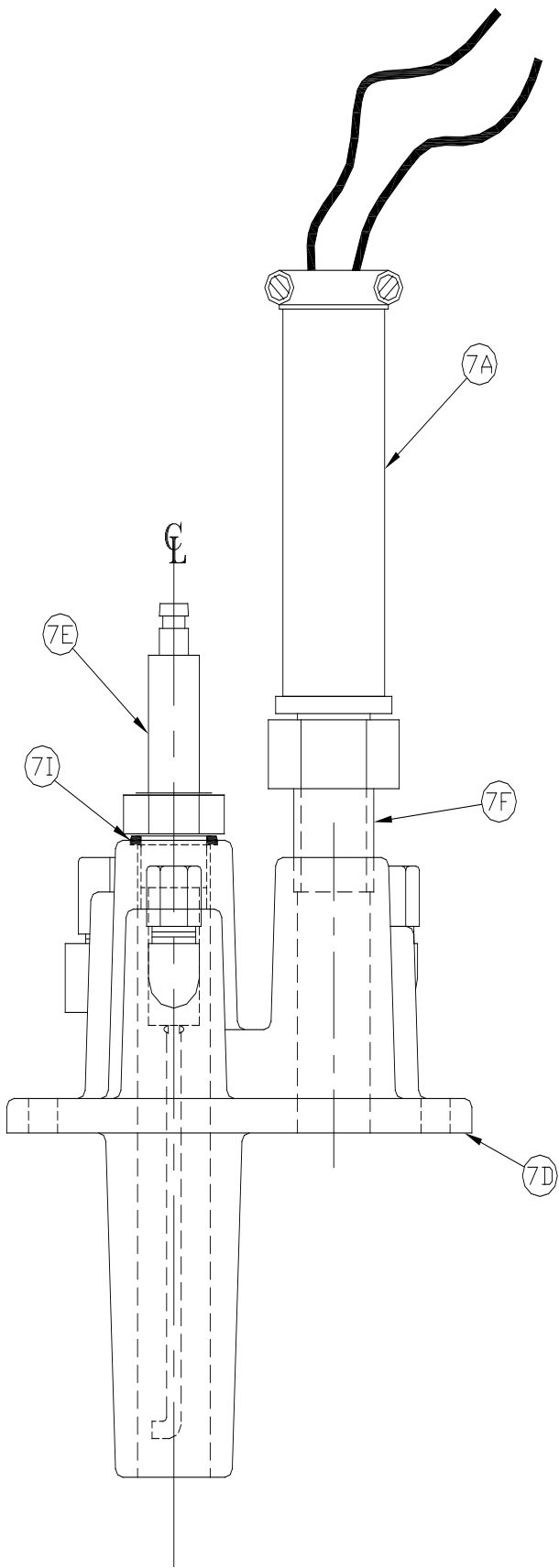
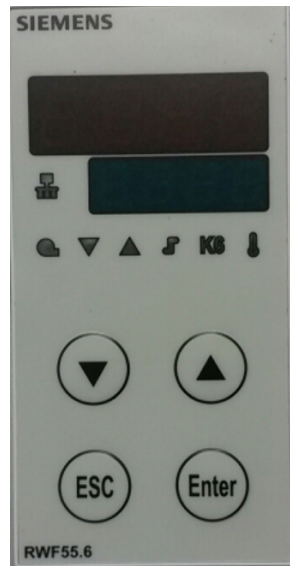

Figure 23: "Bishop" Pilot Assembly

PILOT ASSEMBLY (Bishop Design)				
Key No.	Description			
		EVO-750	EVO-1000	EVO-1500
Pilot Assembly, Bishop				
—	Pilot Assembly Natural Gas, ULZ2	(1) 62356110		
—	Pilot Assembly Propane, LUX2	(1) 62356210		
7A	Ultraviolet Sensor	(1) 8026145		
7B	Pilot Orifice Natural Gas	(1) 722606		
	Pilot Orifice Propane	(1) 722605		
7C	Pilot Air Orifice	(1) 722607		
7D	Cast Iron Body	(1) 82361581		
7E	Igniter Assembly, ULX2	(1) 82356009		
7F	Nipple, 1/2 NPT x Close	(1) 806600040		
7G	Pilot Ignition Cable (not shown)	(1) 103827-01		
7H	Pilot Solenoid Valve V4046C1047 (not shown)	(1) 81660204		
7I	O-Ring	(1) 8206054		

VIII. Temperature Controller Operation



A. Description

The microprocessor based temperature controller is utilized for all modulating Thermal Solutions water heaters. The basic function of the controller is to modulate the firing rate of the burner in response to the heat load. The controller monitors the outlet water temperature through the use of a sensor located in the pressure vessel. The controller compares the outlet water temperature to the controller's user defined operating set-point temperature.

An output signal from the microprocessor varies the blower speed through the use of a variable frequency drive (VFD). The gas valve regulates an appropriate amount of gas flow for a given air flow or blower speed. The user may adjust the operating set-point temperature for a given application. In addition, the controller has the ability to change to an alternate set-point through an external signal for low load conditions (i.e. weekend use, night setback). Outdoor reset is another standard feature, allowing the operating temperature to vary based on the outdoor ambient temperature. The typical result is a higher seasonal efficiency.

Other features include:

Low Fire Hold	Multiple Analog Inputs
Multiple Set Points	Mod Bus Communications
Digital Inputs	Manual Override
"AUTO TUNE" Optimization	

B. Set-Up

All of the control parameters have been set at the factory. There are a few parameters called "Process Parameters" that must be defined by a qualified operator. The table below will help serve as a reference and record when making adjustments.

Parameter	Display	Value Range*	Factory Setting	User Setting
Setpoint 1	SP1	145-240	180	
Setpoint 2	SP2	145-240	0	
Digital Setpoint Shift (optional)	dSP	145-240	0	

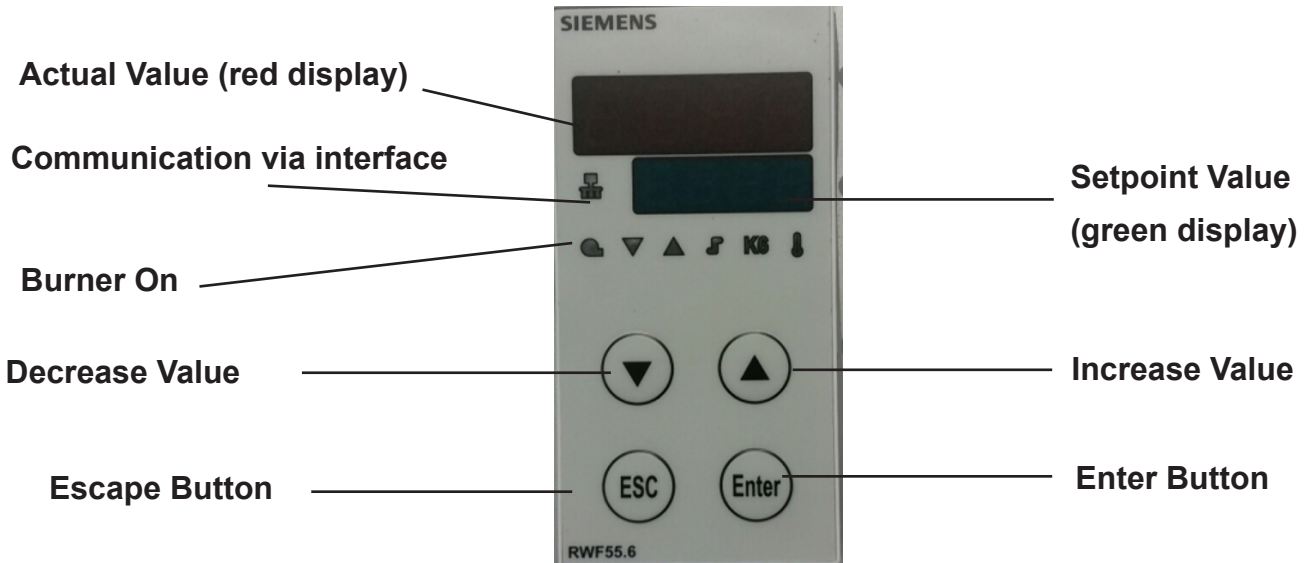

To alter any of these process parameters follow the following steps:

- To obtain access into the programming mode of the controller, briefly press the button “**Enter**”, so OPr is displayed on the second line in green LEDs.
- Press “**Enter**” again so that “SP1” appears. Press “**Enter**” once more so “SP1” flashes. The previously set operating temperature will be displayed on the first line in red LEDs.
- To increase or decrease the setpoint 1 value (SP1) use the up and down arrow keys respectively (▲▼). Press “**Enter**” to confirm.
- To set the value for “SP2”, briefly press the “downward” key so “SP2” appears, then follow the same instructions as above.
- To return to the operating mode press “**ESC**”, otherwise the unit will automatically return to the operating mode after 30 seconds of no activity.

To make other adjustments, contact your local representative or consult the factory.

C. Adjustments

Often during troubleshooting conditions it may become necessary to manually adjust the firing rate. Follow the instructions below to make manual firing rate adjustments.

- Press “**ESC**” button and hold for 5 -10 seconds.
- “Hand” will appear on the lower display, flashing between that and the firing rate value.
- Press ▲ button to raise firing rate. Press ▼ button to lower firing rate.
- 0 = Minimum firing rate and 100 = Maximum firing rate. Press “Enter” to confirm.
- Press “**ESC**” button and hold for 5 –10 seconds to return to automatic firing rate control.
- Automatic mode has been re-activated once the setpoint 1 value is displayed in green LEDs.

D. Other

System Specifications

Input voltage	110-240vac +10-15, 48/63hz
Transducer supply	24VDC, 30ma
Analog Input 1	Pt100,Ni100, Thermocouple (J, K, T or N),4-20ma and Analog 0-10v
Analog Input 2	1k pot,4-20ma, 0-1VDC, 0-10 VDC
Analog Input 3	Pt100,Ni100 Temperature sensors
Output 1 release to modulate-2	4-240VAC 2Amps max
Output 2 and 3 open/close	24-240VAC 2Amps max
Output 4 programmable	24-240VAC 2Amps max
Output 5 analog output	0-10 VDC (500 ohm load min), 0-20 or 4-20ma (500ohm load max)
Mod bus RS485	4800, 9600, 19200, 38400 baud
Data storage	EEPROM
Approvals	UL, CSA, CE

Thermal Solutions

("seller")

LIMITED WARRANTY

LIMITED WARRANTY

Subject to the terms and conditions herein and except as provided below with respect to products or parts not manufactured by Thermal Solutions, Seller warrants to the original owner at the original installation site that products manufactured by Seller ("Products") comply, at the time of manufacture, the heat exchanger with recognized hydronics industry regulatory agency standards and requirements then in effect and will be free from defects in materials and workmanship for a period of 5 years from date of shipment (the "Warranty Period"). The burner is also covered under the limited warranty for 10 years from date of shipment (the "Warranty" Period).

For products or parts not manufactured by Thermal Solutions, the warranty obligations of Thermal Solutions shall, in all respects, be limited to one year.

REMEDY

- A. The sole remedy for breach of this warranty is expressly limited to the repair or replacement of any part found to be defective under conditions of normal use within the Warranty Period. Labor for removal and/or installation is not included.
- B. Warranty - The owner must notify the original installer of the Product and Seller (Attention: Thermal Solutions, P.O. Box 3244, Lancaster, PA 17604-3244), in writing, within the Warranty Period, providing a detailed description of all claimed defects. Transportation to a factory or other designated facility for repairs of any products or items alleged defective shall, in all events, be the responsibility and at the cost of the owner.

EXCLUSIONS

Seller shall have no liability for and this warranty does not cover:

- A. Incidental, special or consequential damages, such as loss of the use of products, facilities or production, inconvenience, loss of time or labor expense involved in repairing or replacing the alleged defective Product.
- B. The performance of any Product under conditions varying materially from those under which such Product is usually tested under industry standards as of the time of shipment.
- C. Any damage to the Product due to abrasion, erosion, corrosion, deterioration, abnormal temperatures or the influence of foreign matter or energy.
- D. The design or operation of owner's plant or equipment or of any facility or system of which any Product may be made a part.
- E. The suitability of any Product for any particular application.

- F. Any failure resulting from misuse, modification not authorized by Seller in writing, improper installation or lack of or improper maintenance.
- G. Equipment furnished by the owner, either mounted or unmounted, or when contracted for by the owner to be installed or handled.
- H. Leakage or other malfunction caused by:
 - 1. Defective installations in general and specifically, any installation which is made:
 - a. in violation of applicable state or local plumbing housing or building codes,
 - b. without a certified ASME, pressure relief valve, or
 - c. contrary to the written instructions furnished with the unit
 - 2. Adverse local conditions in general and, specifically, sediment or lime precipitation in the tubes and/or headers or corrosive elements in the atmosphere.
 - 3. Misuse in general and, specifically, operation and maintenance contrary to the written instructions furnished with the unit, disconnection, alteration or addition of components or apparatus, not approved by seller, operation with fuels or settings other than those set forth on the rating plate or accidental or exterior damage.
- I. Production of noise, odors, discoloration or rusty water.
- J. Damage to surrounding area or property caused by leakage or malfunction.
- K. Costs associated with the replacement and/or repair of the unit including: any freight, shipping or delivery charges, any removal, installation or reinstallation charges, any material and/or permits required for installation reinstallation or repair, charges to return the appliance and or components.

Seller's liability under this warranty shall not in any case exceed the amount paid for the Product found to be defective.

THIRD-PARTY WARRANTIES

For goods or components not manufactured by Seller, the warranty obligations of Seller shall, in all respects, conform and be limited to one year from the date of shipment

SEVERABILITY

To the extent that any provision of this warranty would be void or prohibited under applicable law, such provisions shall be limited in effect to the minimum extent necessary to render the remaining provisions hereof enforceable.

